

the future of space conditioning

Company Profile

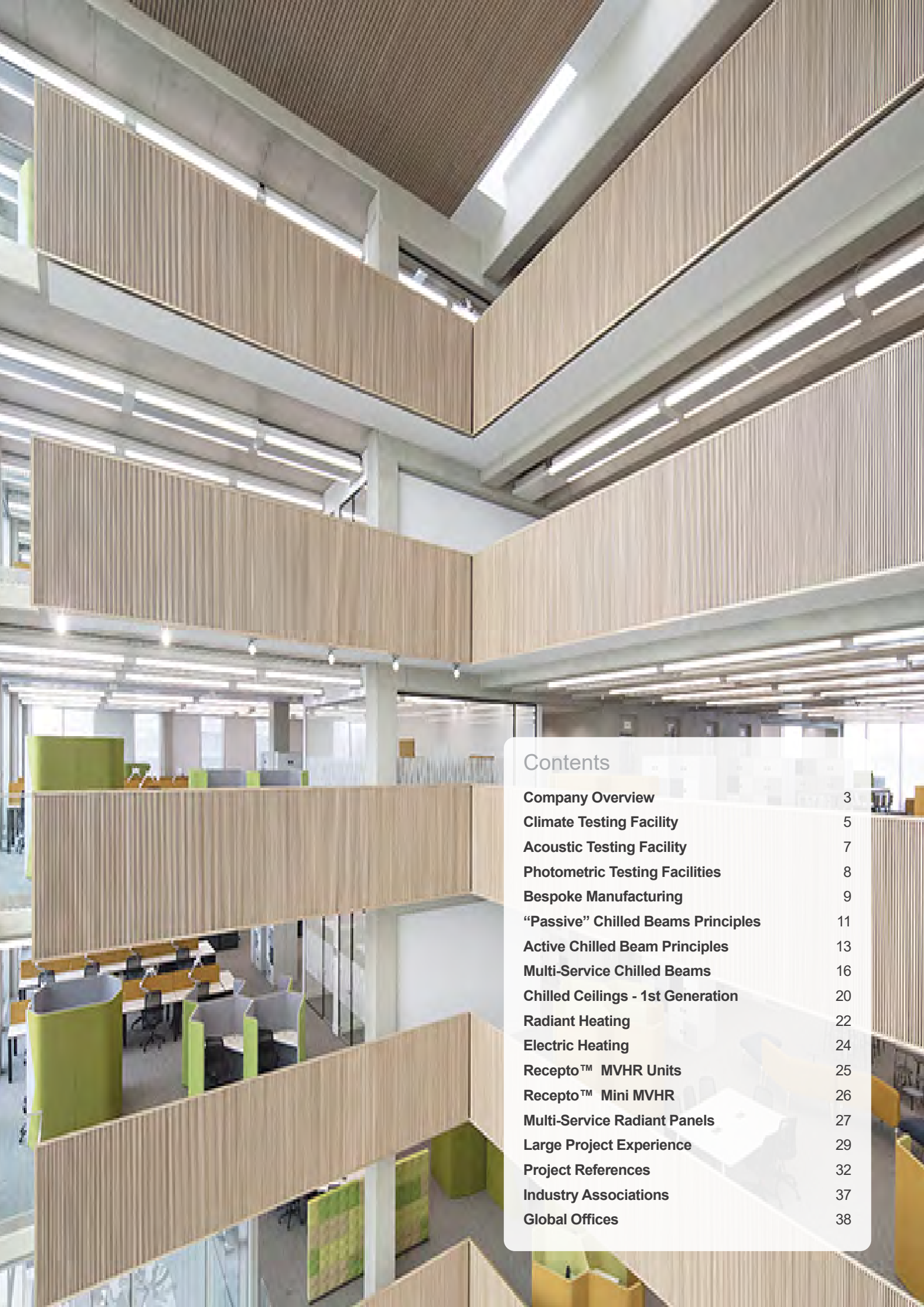



Contents

Company Overview	3
Climate Testing Facility	5
Acoustic Testing Facility	7
Photometric Testing Facilities	8
Bespoke Manufacturing	9
“Passive” Chilled Beams Principles	11
Active Chilled Beam Principles	13
Multi-Service Chilled Beams	16
Chilled Ceilings - 1st Generation	20
Radiant Heating	22
Electric Heating	24
Recepto™ MVHR Units	25
Recepto™ Mini MVHR	26
Multi-Service Radiant Panels	27
Large Project Experience	29
Project References	32
Industry Associations	37
Global Offices	38

Company Overview

Frenger Systems limited is a wholly owned subsidiary of the FTF Group. Frenger Systems is a world-renowned specialist manufacturer of space conditioning products for indoor climate / environments. Frenger has extensive experience dating back some 80 years and is at the forefront of the design, development and manufacture of water driven cooling and heating technologies. Over the years Frenger has earned an enviable reputation as a dependable supply partner capable of developing effective space conditioning solutions for the most complex of projects.

In 1962 Frenger designed, supplied and installed the “World’s Largest Radiant Chilled Ceiling” system which was revolutionary at the time. This consisted of 175,000 square meters of radiant chilled ceiling over the 27 storeys of the Shell Oil headquarters, situated on the river Thames in London. The Thames water was used via secondary heat exchangers to cool the water that circulated on a closed circuit around the ceilings within the building. This building was also the first fully sealed air conditioned building in Europe. This installation operated in excess of 50 years and was a testament to the integrity of the product and to Frenger’s design capabilities.

Frenger also pioneered with the supply of Chilled Beam and Ceiling Technology to Australia in 2003 and this was for the first ever building to be awarded a 5 star energy rating. The building was called “The Bond”, situated in Sydney and developed by Bovis Lend Lease (BLL); whom are now known as Lend Lease.

BLL spent considerable time researching Chilled Beam and Ceiling Technology worldwide and undertook a great amount of due diligence before selecting a Chilled Beam supplier for their then highly confidential building (“The Bond”, 30 Hickson Road, Sydney). Many of BLL’s competition thought that it was not possible to gain a 5 star energy rating and as such BLL knew that the stakes were extremely high and much depended upon their success. Frenger were chosen by BLL to play an integral part of what transpired to be a successful process, the building is still functioning well many years later and coping with external temperatures in the region of 40°C for some parts of the year.

Since 2003 Frenger has supplied Chilled Beam technology to many 5 star and even 6 star energy rated buildings more recently in Australasia, some of these can be seen on pages 29 to 33 of this Company Profile under the title of “Project References”.

In addition to Frenger providing the first Chilled Ceiling in 1962 and providing the first ever 5 star energy rated building in 2003, Frenger pioneered with Multi Service Chilled Beams (“MSCB’s”) in the UK and having designed, supplied and often installed many successful MSCB projects. Frenger were selected by Blyth and Blyth for the £160 Million refurbishment of London & Regionals “55 Baker Street” building which involved HBG Construction (now known as BAM Construction) amalgamating three separate buildings into one enormous building with two central atrium’s and two internal streets.



Frenger designed, Climactic Tested (full scale laboratory mock up), manufactured and installed these MSCB's in 2007 which represented circa 7 million GBP order value to Frenger. This was and still is the world's largest MSCB installation. HBG's annual award for Best Sub-Contractor was also awarded to Frenger and Frenger also gained various letters of commendation from the Client, the Consulting Engineers and the Main Contractor regards their performance of their involvement with the 160 million GBP refurbishment project. Details of this can be found on page 24 of this Company Profile under the heading "Large Project Experience".

The reason as to why Frenger are chosen for such important high profile and complex projects for the space conditioning / indoor climate is because Frenger:

- Have the highest performing products on the market.
- Excellent product quality.
- Always deliver on what is promised and never over state/over sell.
- Have everything in-house to substantiate all aspects of the indoor environment.
- Manufacture as many key items in-house as possible to keep full control.
- Take ownership to deliver what is required, on time, on budget and to the correct specification.

Frenger employs professionally qualified Mechanical Engineers, Electrical Engineers, Lighting Designers, Building Services Engineers and Project Managers to give customers an unrivalled level of in-house expertise for Chilled Beam and Multi-Service Chilled Beam (MSCB) technologies. Frenger builds sound business relationships with clients and has won many accolades to this extent, which has warranted Frenger a justifiable reputation for delivering complex projects on time, within budget and to specification, every time. **All aspects of the business are accredited to BS EN ISO9001:2015 and are regularly audited by the British Standards Institution (BSI).**

Due to Frenger's continuing success, the shareholders of its parent company, the FTF Group, provided Frenger in 2009 with one of their fully owned multi million GBP buildings for fit out as a new Technical Facility. The building is situated in the East Midlands, UK and holds a prominent position on the prestigious Pride Park corporate business centre. Frenger have equipped this building to support all technical aspects of the companies' world wide operations.

The new headquarters are fully space conditioned with various different types of Chilled Beam, MSCB and Chilled Ceiling technologies, each controlled by a full building management system (BMS) which can demonstrate exactly how well each chilled system is functioning and their efficiencies. This building also houses Frenger's:

- Specialist manufacturing.
- State-of-the-art Climactic Test facilities.
- Photometric test laboratories.
- Acoustic laboratory.
- Thermal imaging capabilities.
- Lighting design capabilities.
- 2D & 3D CAD operations.
- Computational fluid dynamics.
- Solidworks.

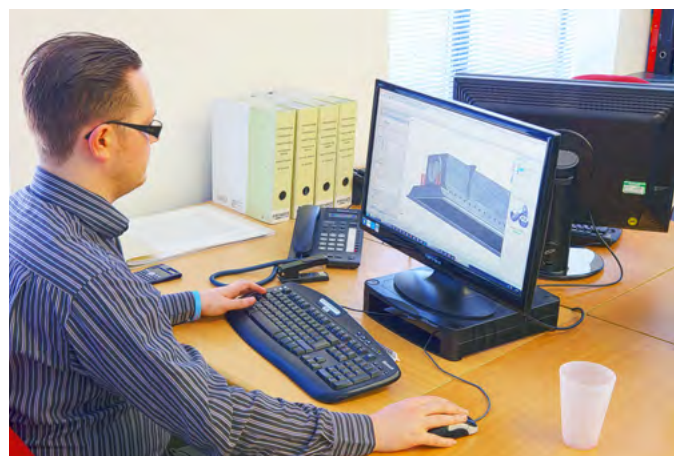
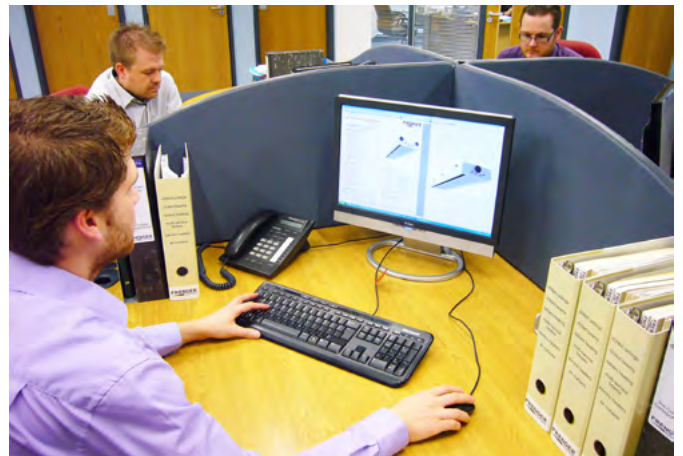

Climate Testing Facility

Frenger has three climatic test laboratories located at its technical centre which is located at the prestigious Pride Park, Derby, England.

These purpose designed and built laboratories have nominal internal dimensions of 6.3m (L) x 5.7m (W) x 3.2m (H) and each environmental chamber includes its own thermal wall so that both core and perimeter zones can be physically modelled in any of the rigs.

All three environmental chambers are fixed in size however the fitment of partition walling and false ceilings can be positioned to match the physical constraints of a project specific installation. Frenger also have in-house thermal imaging capabilities.

Catalogue Data - Standard Product

All Frenger's products are designed by Frenger's in-house Research and Development (R & D) department. Once any new product is ready for mass production these are tested in-house to the following British Standards for Catalogue Data to be collated / published:

- BS EN 14240:2004 – Ventilation for buildings – Chilled ceilings – Testing and rating.
- BS EN 14518:2005 – Ventilation for buildings – Chilled beams – Testing and rating of passive chilled beams.
- BS EN 15116:2008 – Ventilation in buildings – Chilled beams – Testing and rating of active chilled beams.
- BS EN 14037-2 – Radiant Panel Test Methods for Thermal Output.
- ISO 7730 – Ergonomics of the indoor environment.

In addition to the above in-house comprehensive testing which utilises state of the art equipment and BSRIA calibrated instrumentation to reduce the amount of uncertainty to an accuracy of $\pm 2.5\%$, Frenger also subscribe to third part Validation Testing by Eurovent.

Eurovent certification testing is only for performance and takes no account of the indoor environment, whereas all Frenger testing and published catalogue data is compliant to **ISO 7730** (Technical data available to download from Frenger's website under 'Technical Downloads'. TDS 04A & TDS244), ergonomics of the indoor environment to ensure that occupancy comfort is maintained to the highest of standards.



1 of 3 climatic test laboratories

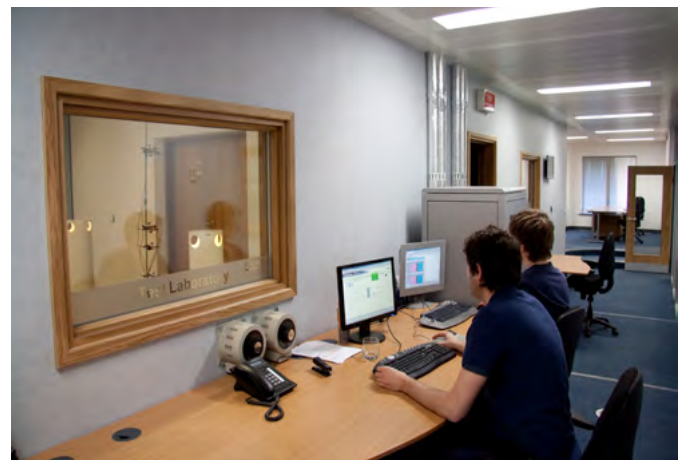

Project Specific Testing

Project specific mock-up testing is a valuable tool which allows the Client to fully assess the proposed system and determine the resulting indoor quality and comfort conditions; the physical modelling is achieved by installing a full scale representation of a building zone complete with internal & external heat gains (Lighting, Small Power, Occupancy & Solar Gains).

The installed mock-up enables the client to verify the following:

- Product performance under project specific conditions.
- Spatial air temperature distribution.
- Spatial air velocities.
- Experience thermal comfort.
- Thermal imaging (still images and video footage).
- Project specific aesthetics.
- Experience lighting levels (where relevant).
- Investigate the specific design and allow the system to be enhanced.

The project-specific installation and test is normally conducted to verify:

- Product capacity under design conditions.
- Comfort levels - Air temperature distribution.
 - Thermal stratification.
 - Draught risk.
 - Radiant temperature analysis.
- Smoke test video illustrating air movement.

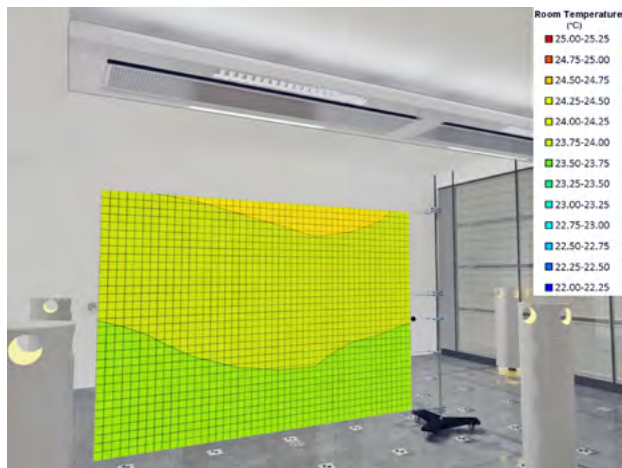

Active MSCB Room Temperature

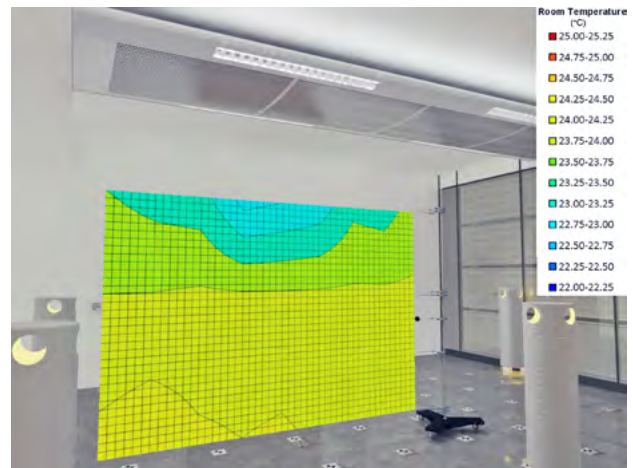

Radiant Passive MSCB Room Temperature

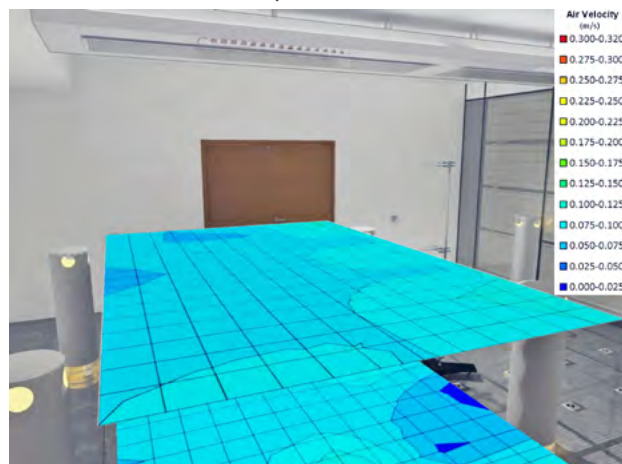

Active MSCB Air Velocity

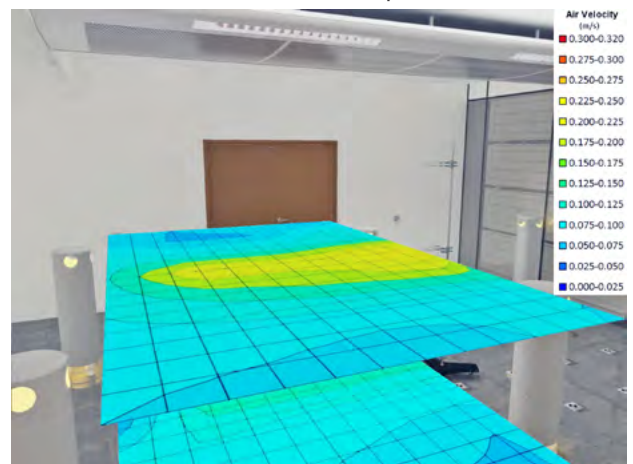

Radiant Passive MSCB Air Velocity

Acoustic Testing Facility

The Acoustic Test Room at Frenger is a hemi-anechoic chamber which utilises sound absorbing acoustic foam material in the shape of wedges to provide an echo free zone for acoustic measurements; the height of the acoustic foam wedge has a direct relationship with the maximum absorption frequency, hence Frenger had the acoustic wedges specifically designed to optimise the sound absorption at the peak frequency normally found with our active chilled beam products.

The use of acoustic absorbing material within the test room provides the simulation of a quiet open space without “reflections” which helps to ensure sound measurements from the sound source are accurate, in addition the acoustic material also helps reduce external noise entering the test room meaning that relatively low levels of sound can be accurately measured.

The acoustic facilities allow Frenger to provide express in-house sound evaluation so that all products, even project specific designs can be quickly and easily assessed and optimised.

To ensure accuracy, Frenger only use Class 1 measurement equipment which allows sound level measurements to be taken at 11 different $\frac{1}{3}$ octave bands between 16 Hz to 16 kHz, with A, C and Z (un-weighted) simultaneous weightings.

In addition to the above, Frenger also send their new products to specialist third party Acoustic Testing. The results of which are very close and within measurement tolerances to that of Frenger’s in-house measurement of sound.

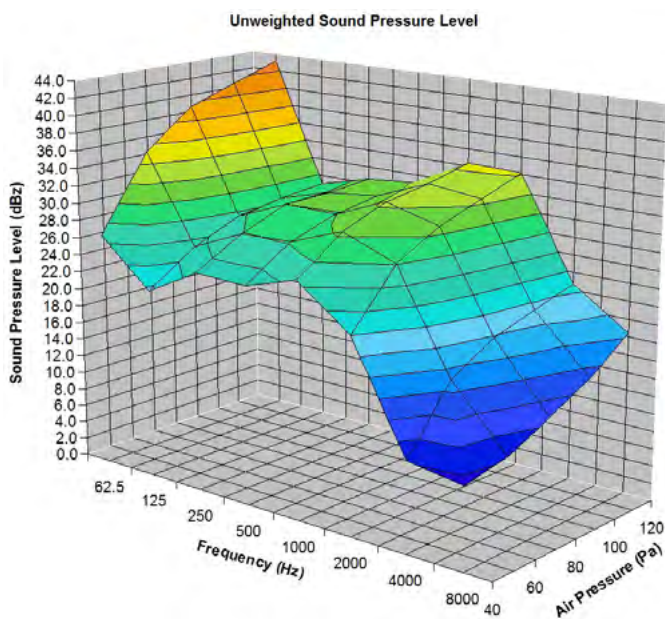
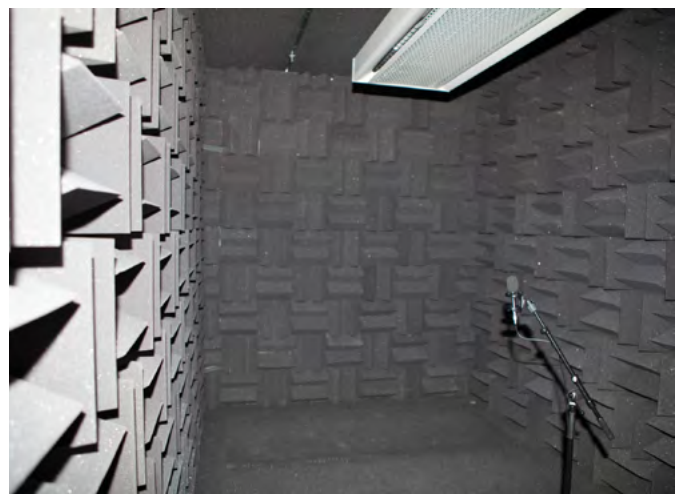
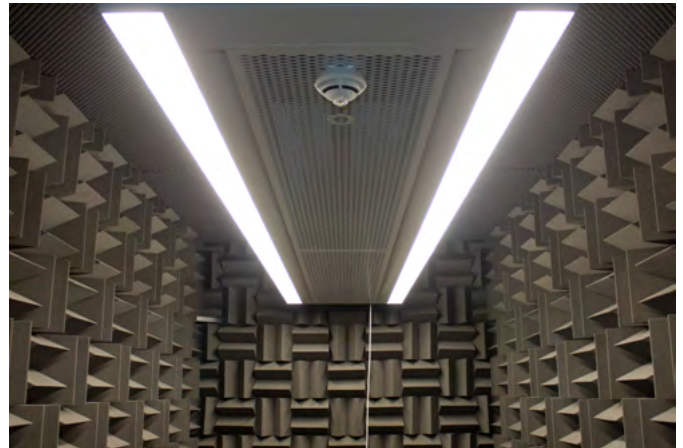

Photometric Testing Facilities

The in-house Photometric test laboratories at Frenger are used to evaluate the performance of luminaires. To measure the performance, it is necessary to obtain values of light intensity distribution from the luminaire. These light intensity distributions are used to mathematically model the lighting distribution envelope of a particular luminaire. This distribution along with the luminaires efficacy allows for the generation of a digital distribution that is the basis of the usual industry standard electronic file format. In order to assess the efficacy of the luminaire it is a requirement to compare the performance of the luminaire against either a calibrated light source for absolute output or against the “bare” light source for a relative performance ratio.

The industry uses both methods. Generally absolute lumen outputs are used for solid state lighting sources and relative lighting output ratios (LOR) are used for the more traditional sources. Where the LOR method is chosen then published Lamp manufacturer’s data is used to calculate actual lighting levels in a scheme and for LED light source the integration chamber is used to measure LED luminance efficacy.

The intensity distribution is obtained by the use of a Goniophotometer to measure the intensity of light emitted from the surface of the fitting at pre-determined angles. The light intensity is measured using either a photometer with a corrective spectral response filter to match the CIE standard observer curves or our spectrometer for LED sources.

Luminaire outputs are measured using our integrating sphere for smaller luminaires or our large integrator room for large fittings and Multi Service Chilled Beams. For both methods we can use traceable calibrated radiant flux standards for absolute comparisons.

All tests use appropriate equipment to measure and control the characteristics of the luminaire and include air temperature measurements, luminaire supply voltage, luminaire current and power. Thermal characteristics of luminaire components can be recorded during the testing process as required.

A full test report is compiled and supplied in “locked” PDF format. Data is collected and correlated using applicable software and is presented electronically to suit, usually in Eulumdat, CIBSE TM14 or IESN standard file format.

Frenger conduct photometric tests in accordance with CIE 127:2007 and BS EN 13032-1 and sound engineering practice as applicable. During the course of these tests suitable temperature measurements of parts of LED’s can be recorded. These recorded and plotted temperature distributions can be used to provide feedback and help optimise the light output of solid state light source based luminaires which are often found to be sensitive to junction temperatures.

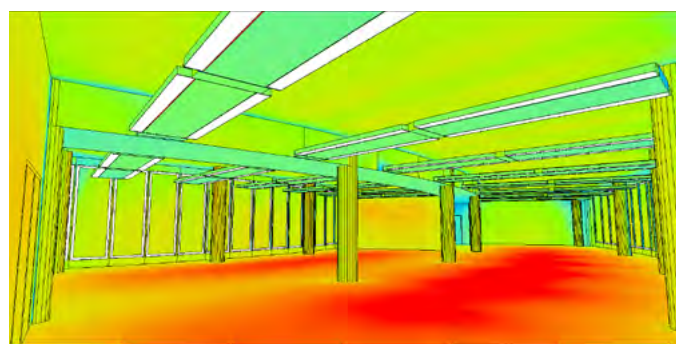
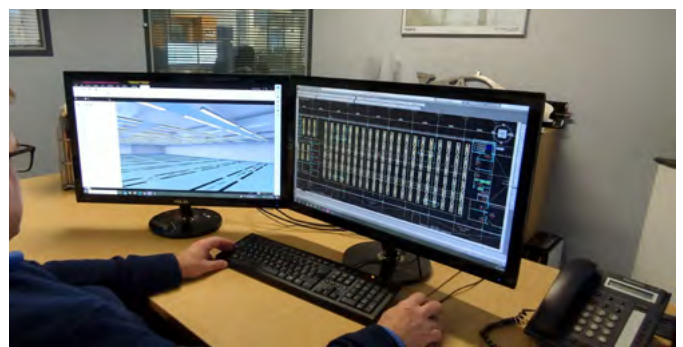
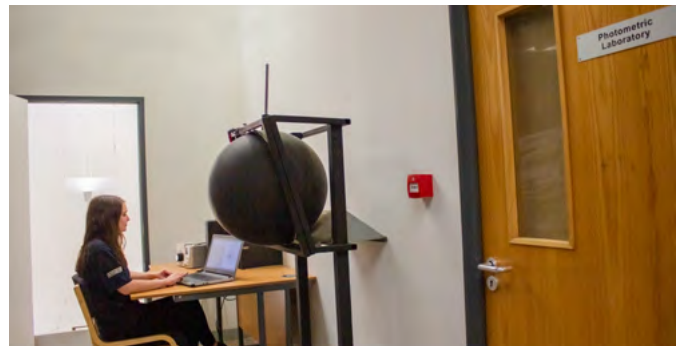

Bespoke Manufacturing

The Company has the manufacturing capability required to deliver the most complex of bespoke solutions. Facilities include the latest full CNC bending centers and machining equipment, together with a dedicated powder-coat paint plant to paint all of the components of the Multi-Service Chilled Beam.





“Passive” Chilled Beams Principles

Frenger has extensive experience in the design and manufacturing of “Radiant” / Convective Passive Chilled Beam solutions; providing discreet and cost-effective space conditioning to commercial, educational and healthcare environments. Over the past 20 years products have been supplied to major projects throughout Europe, and as far afield as Australia. **Frenger’s “Radiant” / Convective Passive Chilled Beams offer a hybrid between Conventional Passive Chilled Beams and Radiant Chilled Ceiling.**

Low maintenance cooling systems

“Radiant” / Convective Passive Chilled Beams provide an efficient means of cooling and, with no moving parts, require little maintenance. This in turn ensures lower running costs. They can be installed above perforated or microperforated metal ceilings to provide up to 150 W/m² of cost-effective cooling with minimal control requirements.

This type of solution does not create any noise or draughts in office environments, and improve both the comfort and is reported to increase the productivity of the occupants. The system ensures a very low degree of air movement below the chilled beams - less than 0.25 m/s - in order to comply with **ISO 7730**. (Technical data available to download from Frenger’s website under ‘Technical Downloads’, TDS 04A & TDS 244)

Operation

When cold water passes through out “Radiant” / Convective Passive Chilled Beam the warm room air is cooled against the surfaces. This chilled air, which then becomes heavier, then streams through the punched louvres in the radiant beam and percolates through the small ceiling perforations into space below (when concealed). In this way air is circulated within the room, with warm air from the room space being continually replaced by cooled air.

In addition to this convective process, the cold surfaces of the beam also absorb heat radiation from the building occupants and the warmer surrounding surfaces. **The radiant quotient is approximately 40% of the total cooling effect (the other 60% of cooling being generated by the convective cooling effect described above).** The ability of our “Radiant” / Convective Passive Chilled Beam to also cool by radiant absorption means that, when compared to a finned tube battery, our beam can deliver 40% more cooling without any additional risk of draught.

In addition to the convective heat transfer common to all Passive Chilled Beams, the radiant effect of the products also cools the metal ceiling system (secondary radiation), which in turn re-radiates this cooling effect into the room. **The radiant effect of the beam also provides a more comfortable environment for the building occupants and even less chance of any draughts (draught risk rating is reduced).** The system provides the comfort and aesthetic benefits of radiant chilled ceilings at a significantly lower cost and whilst maintaining the higher cooling capacities associated with chilled beam installations.

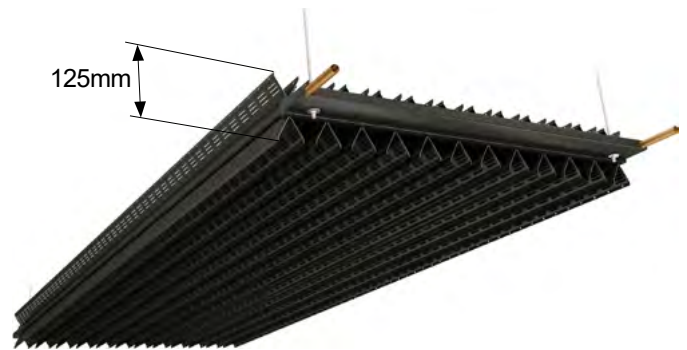

X-Wing® (Radiant Chilled Beam)

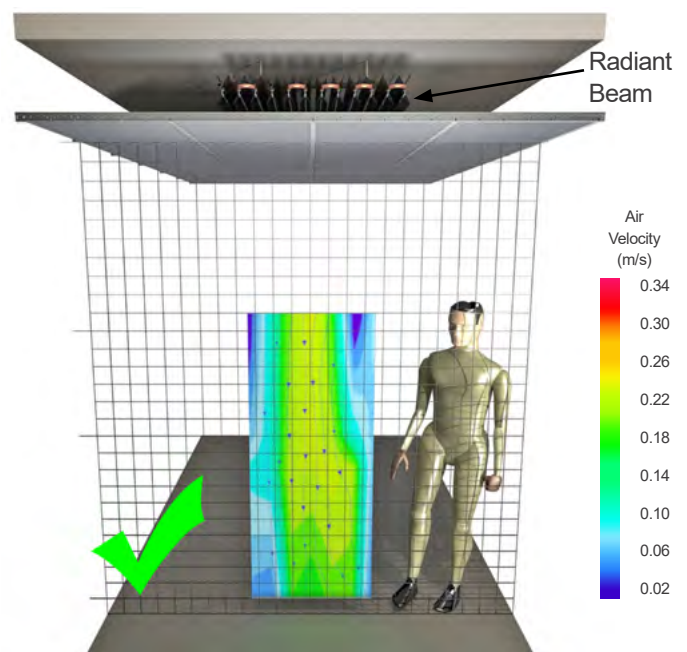

Radiant Chilled Beam

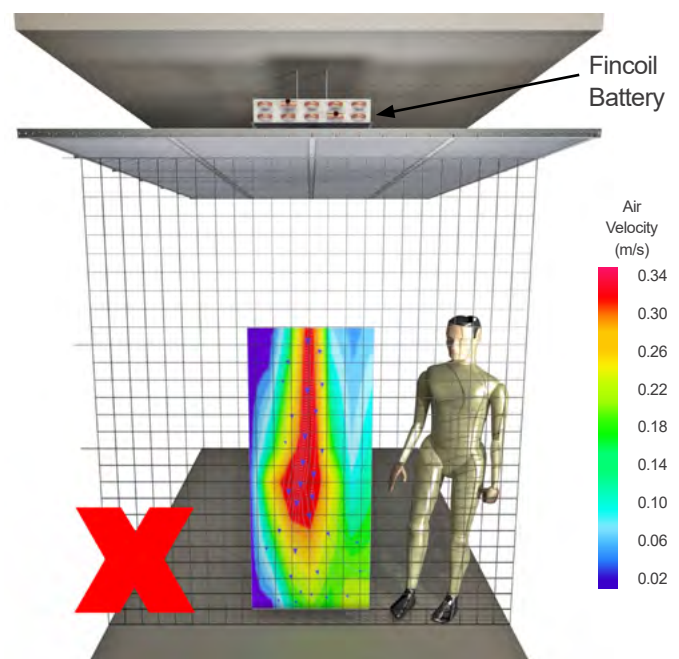

Convective Only Fincoil Battery

Composition and manufacture

Frenger's "Radiant" / Convective Passive Chilled Beams are constructed from coiled copper which is formed into serpentine coils utilising full CNC, state-of-the-art automated de-coiling and bending machines. **This process eliminates the risk of any leaks as there are no joints in the copper water circuit of the product.** The aluminium radiant "wings" which make up the cooling surface are mechanically fixed around the copper tube serpentine one piece coil in which the cold water is transported to provide 100% encapsulation of the waterways for optimum transfer of energy from the radiant wings to the copper waterways. **Both the copper tubing and aluminium wings are 100% recyclable.**

Dimensions

Frenger "Radiant" / Convective Passive Chilled Beams are compact and versatile in the way that they can be mounted and located. Available in different widths and lengths and is only 125mm deep, systems can be installed in 255mm ceiling voids.

Benefits of "Radiant" / Convective Chilled Beams

- **No joints in the copper tube coil - no risk of leaks.**
- No noise or draughts; improved occupancy comfort and productivity.
- No moving parts equates to reduced maintenance costs.
- Capital costs now comparable and / or more competitive than traditional AC systems.
- Improved efficiencies translates to lower running costs.
- Can be installed within shallow ceiling voids.

Frenger's unique features

- **Only 125mm deep.**
- Offers radiant and convective cooling.
- Will operate efficiently above a micro-perforated ceiling.
- Can be installed within a 255mm deep total ceiling construction, if necessary due to height restrictions.
- Minimal maintenance due to absence of closely spaced fins as associated with fincoil battery passive beams.
- Very low air movement below chilled beam.
- Cooling capacity up to 150 W/m² above metal ceiling perforated to 28% free area and 2.4mm or 3.0mm perforation.

Commercial Offices

Frenger's range of "Radiant" / Convective Passive Chilled Beams installed above perforated metal ceiling systems is a tried and tested solution used in many high-profile projects in the UK, Europe and Australia. The system provides high levels of comfort for occupants, with minimal control and maintenance requirements.

Furthermore, the Radiant / Convective nature of the product means that it is insensitive to the position of heat sources, and can be utilised with standard ceiling perforation patterns for greatly improved aesthetics.

Maintenance

Frenger's range of "Radiant" / Convective Passive Chilled beams are extremely easy to clean, requiring a simple wipe with a damp cloth.

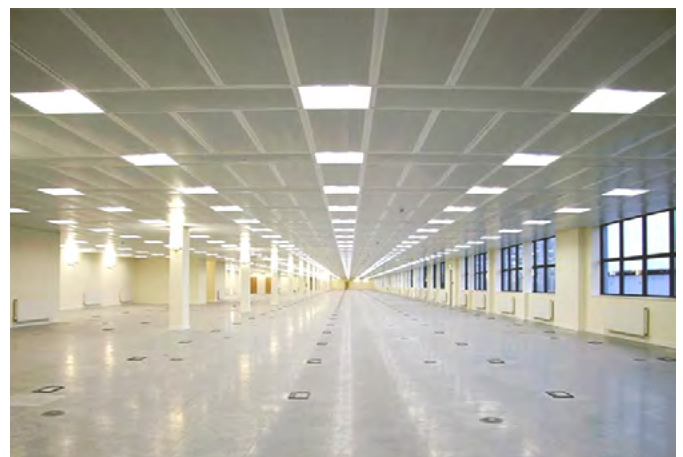
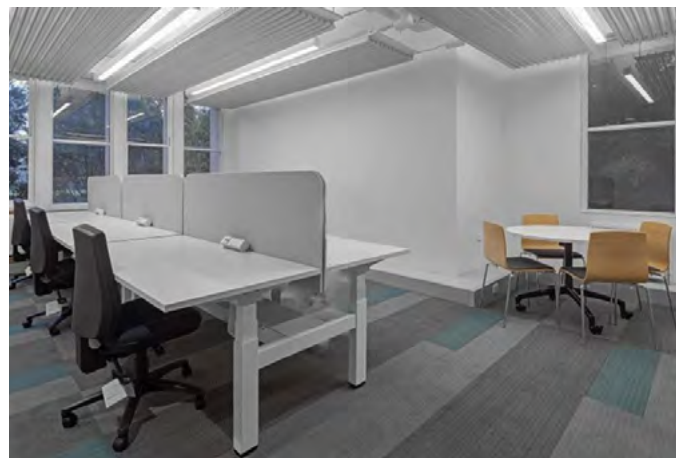

Active Chilled Beam Principles

Frenger manufactures and supplies a range of Active Chilled Beams with the highest performance curves on the market. Frenger draw upon high performance technologies and patented / registered design features to deliver efficient cooling to commercial, educational and health-care environments.

Efficient and quiet space conditioning

Frenger's Patent Protected battery angles, air chamber geometry and unique burst nozzle strip enables their Active Chilled Beams to deliver unrivalled levels of cooling capacity with a given air volume whilst ensuring that the reconditioned air is delivered into the space in a controlled manner that best suits the application. **The units are so efficient that they can provide cooling in excess of 250 W/m with fresh air supply of as little as 1 litre/s/m².**

Units are designed to integrate into suspended ceiling systems. They fit easily into the most common ceiling designs and have removable underplates that can be perforated to match perforated metal ceilings where required or to best compliment mineral fibre or plasterboard ceilings. These removable underplates provide access for maintenance, although maintenance is minimal given that there are no moving parts.

Frenger's Active Beams are also designed to ensure low noise levels. They incorporate a patented air chamber burst nozzle strip technology which delivers cool air to the room very quietly, and makes them suitable for discreet installation in hotels, offices, hospitals, schools and banks. **Air delivery can be accurately controlled so that air velocities do not exceed 0.25 m/s, ensuring compliance with ISO 7730** by use of discrete air deflector vanes mounted as part of the patented and registered designed air chambers. Beams can be supplied with factory fitted condensation sensors.

Operation

An Active Beam is essentially a water driven ceiling-mounted induction unit. It uses a supply of fresh ventilation air to induce warm room air (recirculated air) through the unit's cooling fincoil battery. The Frenger beam is able to induce and condition 4-5 times as much room air as fresh air supplied. Conditioned air is then quietly reintroduced into the room, entraining to the ceiling (when ceiling recessed) rather than being jetted out directly below the beam, thanks to the air chamber design that produces a Coanda effect to occur within the beam casing. The use of Coanda wings for exposed ("free hanging") active chilled beams enables the reconditioned air to have a horizontal discharge to avoid any high air speeds in the occupied zone below. Ordinarily when active beams are exposed ("free hanging") the most popular solution is the integrated lighting within the Coanda wing. Frenger's Patent Protected nozzle technology also allows Frenger to determine and factory-set the airflow dispersion characteristics of each active chilled beam unit. **Beams can deliver a cooling capacity in excess of 1000 W/m.**

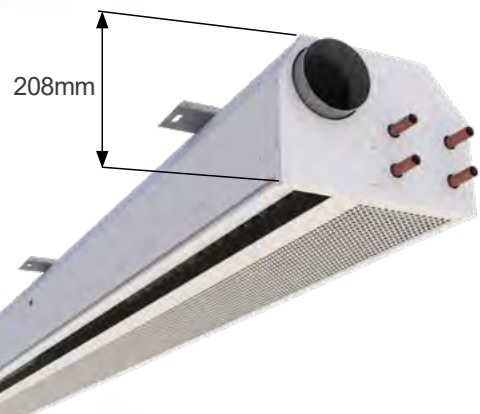
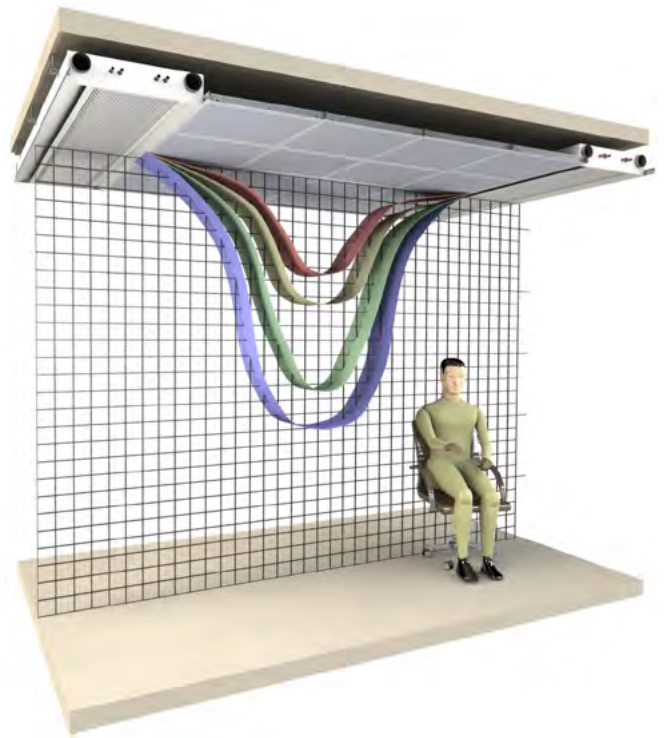

Ultima® One way ceiling discharge

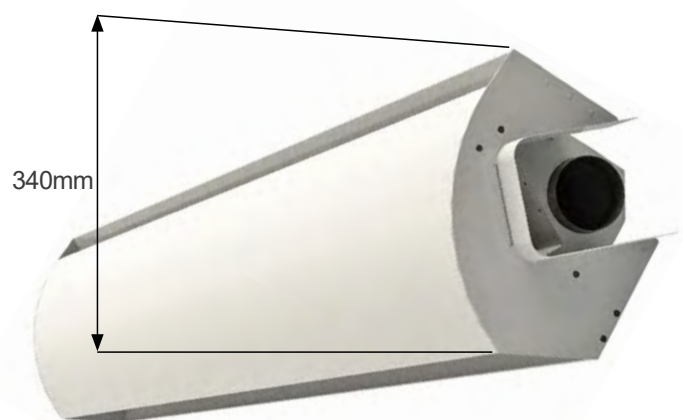

Cornice™ One way ceiling discharge

Composition and manufacture

Air is cooled as it passes through a fin coil battery, which comprises aluminium fins with copper tubes through which water passes. The heat of the room is taken in through the aluminium fins, and transferred into the water circuit through the copper tube and transported away via the circulating chilled water back to a central chiller unit. Active Chilled Beams have no moving parts, and as such maintenance costs are minimal.

Dimensions

The Frenger units have side-mounted air chambers that facilitate high cooling in very compact dimensions. Our slim line beams range which can operate with up to 50 ltrs/sec and is just **133mm deep**, whereas our High Output beam range which can operate with up to 80 ltrs/sec and is just 208mm deep. **Both of which can achieve 1000 W/m total cooling.**

Benefits of active chilled beams

- Units can deliver cooling, heating, fresh air and lighting.
- **A range of beams with 1-way, 2-way and 360 Degree air discharge.**
- No moving parts equates to reduced maintenance costs.
- Capital costs now comparable and / or less than traditional air conditioning systems.
- Improved efficiencies translate to lower running costs.
- Can be installed in shallow ceiling voids.
- Units can deliver cooling capacities in excess of 200 W/m².
- Long life expectancy - in excess of 30 years.

Frenger's unique features

- All recirculated air is induced through the removable underplate and consequently there is no need for a return air path via the ceiling void.
- Advanced Patent Protected battery angle technology delivers induction ratios of 5:1, enabling effective cooling at supply air rates as low as 1 litre/s/m².
- Patent Protected burst nozzle strips design result in optimised heat exchange performance and quiet operation.
- Advanced air chamber design creates a Coanda effect, with air entraining to the ceiling for improved occupancy comfort levels.
- Registered designs for concealed air discharge vanes provide "fan shaped distribution" technology as standard which reduces the risk of high air speeds in the occupied zone providing higher levels of thermal comfort.
- Air delivery can be accurately controlled such that velocities do not exceed the 0.25 m/s as required by ISO 7730.
- Beams can be tailor made to pretty much whatever length, width and configuration a project requires whilst also being fully optimised.

Air Distribution

Frenger's range of Active Chilled Beams have been specifically designed to deliver air into the space in a controlled and predictable manner. **All beams create a Coanda effect in the unit which encourages the supplied air to entrain to the ceiling or soffit, furthermore, units can be manufactured with varying throw characteristics (short, medium or long) and even with different air delivery characteristics from either side of the unit, or at one end of a unit if required.**

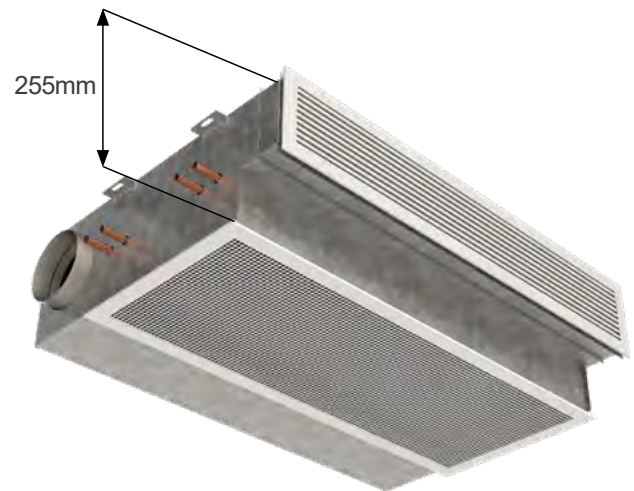

Bulkhead One way ceiling discharge beam



Halo® 600 - 360 degree discharge pattern

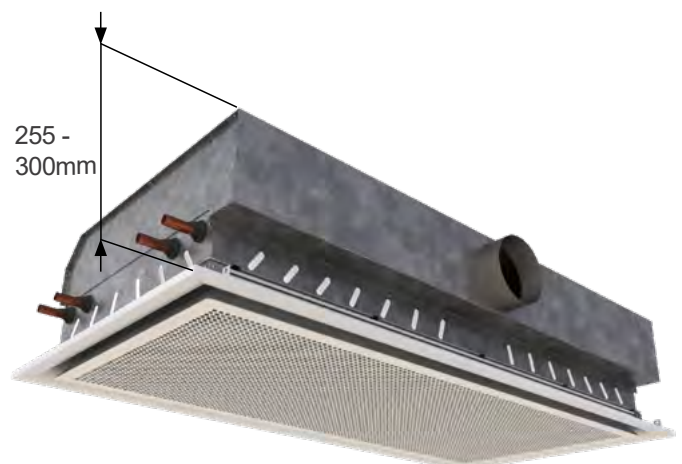

Halo® 1200 - 360 degree discharge pattern

Air Distribution Continued

Air distribution and comfort levels are determined by many factors; supply air temperature, air volume, air pressure, air direction and entrainment (Coanda effect) and beam spacing. Extensive laboratory tests have been undertaken by Frenger in their in-house state-of-the-art climatic test laboratories, to develop a library of empirical data presented in the form of scatter diagrams, which enables the designer to select the most appropriate product configuration for any given condition.

Maintenance

Chilled Beams have no internal moving parts and have little to no maintenance requirements other than periodically cleaning the heat exchanger battery (recommended annually or bi annually for Hospital applications and every 5-10 years for office environments).

All units are provided with simple access to the heat exchanger battery through the Chilled Beams removable underplate - there is no requirement to access the ceiling void for maintenance or cleaning of the Chilled Beam or heat exchange battery.

Eco-Healthcare models have a "drop down battery" that enables the heat exchanger battery to be easily lowered (even whilst the beam is still in operation) for deep cleaning of all 4 sides of the heat exchanger battery and internal casing of the beam - this is particularly popular within hospital applications.

Energy Efficient

An Active Chilled Beam (ACB) system operates on elevated chilled water supply temperatures (designed to run 'dry' ,above dew point ,typically from 14°C to 17°C supply temperature) and have no moving parts (i.e. no fans or motors) which provide for a more energy efficient system when compared to other HVAC system which typically operated below dew point (wet) on a 6°C or 7°C supply temperature (which also means condensate drip trays are required) and are supplied with individual fans and motors. The coefficient of performance (COP) and or EER (energy efficiency ratio) is much higher for Chillers operating on 14/17 degrees (typical COP / EER is 4.5 for a standard chiller) when compared to other HVAC systems operating on 6/12 flow & return (COP / EER is typically 4.0) and with active chilled beam units that run dry you can also make use of 'Free Cooling Chillers' to drastically increase the COP / EER to an average hourly rate of 13.5 for projects based on London weather data.

The total SFP (specific fan power) for an active chilled beam system (in Watts energy used by the AHU for the total system per Ltrs / sec fresh air supplied) is typically much lower than that of other mainstream HVAC system as active chilled beam units have no fans and no additional controls per terminal unit consuming energy all day / every day.

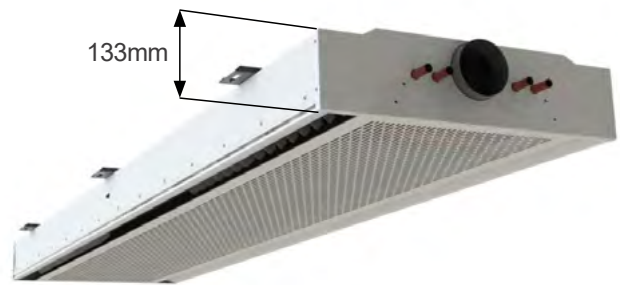
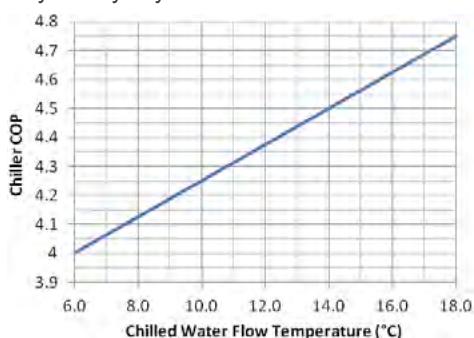

Compact® Two way discharge



Ultima® Two way discharge



Eco HQ™ Two way discharge

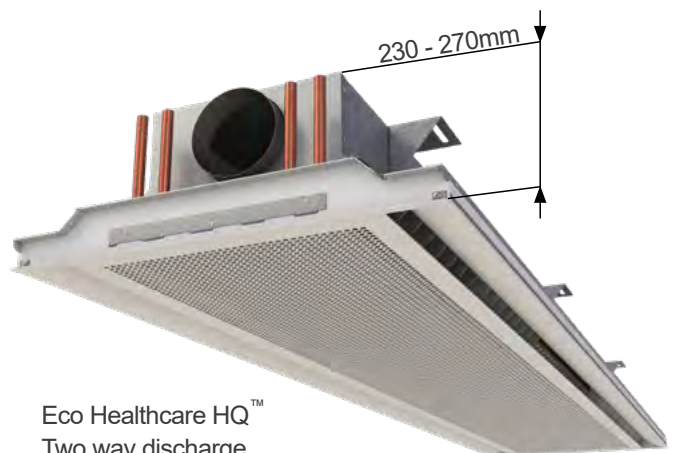

Eco Healthcare HQ™
Two way discharge

Multi-Service Chilled Beams

Frenger manufactures and supplies Multi-Service Chilled Beams (MSCBs). These units are 100% pre-fabricated off site and incorporate the main building services. These pre-fabricated MSCB units can also facilitate free issued services to enable a 'plug and play' installation on site, saving precious time and money. MSCB units provide flexible space conditioning that can be tailored in terms of appearance and the services provided, in order to meet project specific requirements. In this way they help to create attractive, comfortable and productive working environments that create a sense of larger volumetric office space, with higher floor to ceiling heights (given that there is no ceiling void requirements). This can be useful for refurbishment properties where floor to ceiling heights are low, or for new builds where construction costs are reduced or additional lettable floor levels can be created with in the same height building - for more details see technical downloads TFS003 - 'Multi-Service Chilled Beams' under the Technical Downloads section on Frenger's website.

Flexible building service units

A full range of building services can be incorporated within a Frenger Multi-Service Chilled Beam, including:

- Cooling & heating.
- Fresh air supply.
- Uplighting, downlighting and emergency lighting.
- BMS sensors, control valves & condensation detectors.
- Accommodate fire alarms and sprinkler systems.
- Acoustic insulation.
- Pipework, ductwork & compartmental trunking.
- Accommodate PA and VA speaker systems.

Bringing several services together in an integrated MSCB unit means that the physical dimensions of the unit can be optimised to enable use in spaces where the floor-to-slab height is minimal. The concept also provides the specifier with a single source of responsibility for the design, supply and integration of all services "pre-fabricated" offsite in a controlled environment, reducing costs and on-site build program time.

Operation

MSCB's can utilise either "Radiant" Passive or Active Chilled Beam technologies. The cooling units are integrated into perforated architectural casings with either central or side - mounted lighting. Lighting options are varied and could be direct, indirect, a combination direct and indirect, T5 fluorescent, LED's or continuous extruded lighting optics of any shape and size to suit the architectural aspirations of the project. Completed MSCB's are factory tested and delivered to site for "plug and play" mechanical and electrical connection / installation.



Active MSCB



Radiant Passive MSCB



Radiant Passive MSCB



Active MSCB

Operation Continued

Frenger's passive MSCB utilise the company's "Radiant" / Convective products to provide comfortable cooling through a combination of convective and radiant heat transfer processes; warm room air is cooled through contact with the Chilled Beam and diffused into the space through the perforated underplate, the beam casing is also cooled via secondary radiation and thus absorbing heat from the warmer occupants. This type of passive cooling provides the best possible combination of high cooling capacities and exception levels of occupancy comfort with minimal maintenance.

Where there is a need to use the MSCB to deliver fresh air into the space, then Frenger's Slim Line or High Output Active beam products will form the basis for the company's Active MSCB's. Active Beams utilise the delivery of supply air to induce warmer room air through the unit's cooling battery. The technology employed in Frenger's Active Chilled Beams ensures high cooling capacity with low supply air volumes, coupled with a quiet and controlled delivery of air for optimal comfort.

Both types of MSCB are designed for simple installation; electrical, water and air connections can be inter-linked from unit to unit by simple "Plug and Play" connections to reduce on-site time to a minimum.

Technical Support

Frenger can draw upon many years experience in the design and manufacture of cooling systems which combine the highest levels of occupancy comfort with class-leading design. Frenger has a "proven track record" for delivering the highest performing and largest Multi Service Chilled Beam projects in the World, in-house specialist manufacturing, state-of-the-art test facilities and various design operations for all aspects of every service within their MSCB units.

Frenger can offer clients a range of support services here in the UK at their Pride Park Facility;

- Full Climate Testing to predict comfort levels.
- Full lighting design including light level calculations and luminaire development to LG3 / LG7 requirements.
- CAD drafting and 3D rendering of MSCB units in the given environment.
- Solidworks.
- CFD Modelling.
- Energy Modelling.
- BIM Software (Project Specific parabolic models available).
- Revit.



Active MSCB



Radiant Passive MSCB



Radiant Passive MSCB

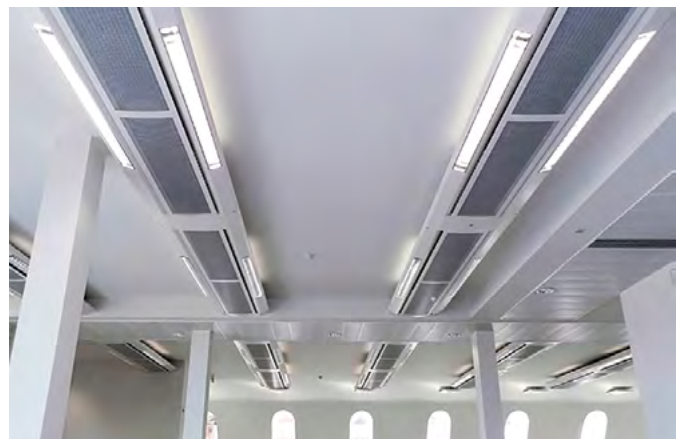

Active MSCB

Benefits of MSCB's

- Ideal where floor-to-slab height is minimal.
- Low running costs with minimal maintenance requirements.
- Integration of several services in a single unit reduces costs and site programme requirements ("pre-fabricated" off site).
- High cooling / heating capacities.
- Low noise and low draught risk makes for high comfort levels.
- Beam aesthetic can be customised to client requirements.
- Single point of responsibility for the design, integration, manufacture and testing of all services ("Plug and Play").

Frenger's unique benefits

- 'In-house' lighting design and luminaire development.
- Passive MSCBs deliver cooling via radiant absorption and convection.
- Active MSCBs deliver high cooling capacities with minimal supply air volume.
- Considerable experience in the design and supply of both active and passive types of MSCB.
- **Only company whom manufacture in-house the services offered and to also have the in-house test facilities for all the services offered.**

In-house Testing Facilities

Frenger also has the following in-house test facilities which enable us to develop and offer clients with bespoke MSCB designs;

- 3 number state of the art Climatic Test Laboratories (BSRIA calibrated) generally in accordance with BS EN 14518:2005, BS EN 15116:2008 and BS EN 14240:2004.
- 1 number Photometric Test Labs along with lighting design in accordance with BS EN 13032 and sound engineering practice.
- 1 number Integration laboratory for establishing Light Output Ratios (LOR) in accordance with BS EN 13032. All data manipulation, correlation and presentation in accordance with CIE 117, CIE 121, CIE 127, BS 5225, BS 354, TM4, TM10, LG7 and EN 60598
- Acoustic testing semi-anechoic chamber which measures Class 1 measurements at 11 different one third octave bands between 16Hz to 16kHz.



Active MSCB



Radiant Passive MSCB



Active MSCB



Radiant Passive MSCB



Active MSCB



Radiant Passive MSCB

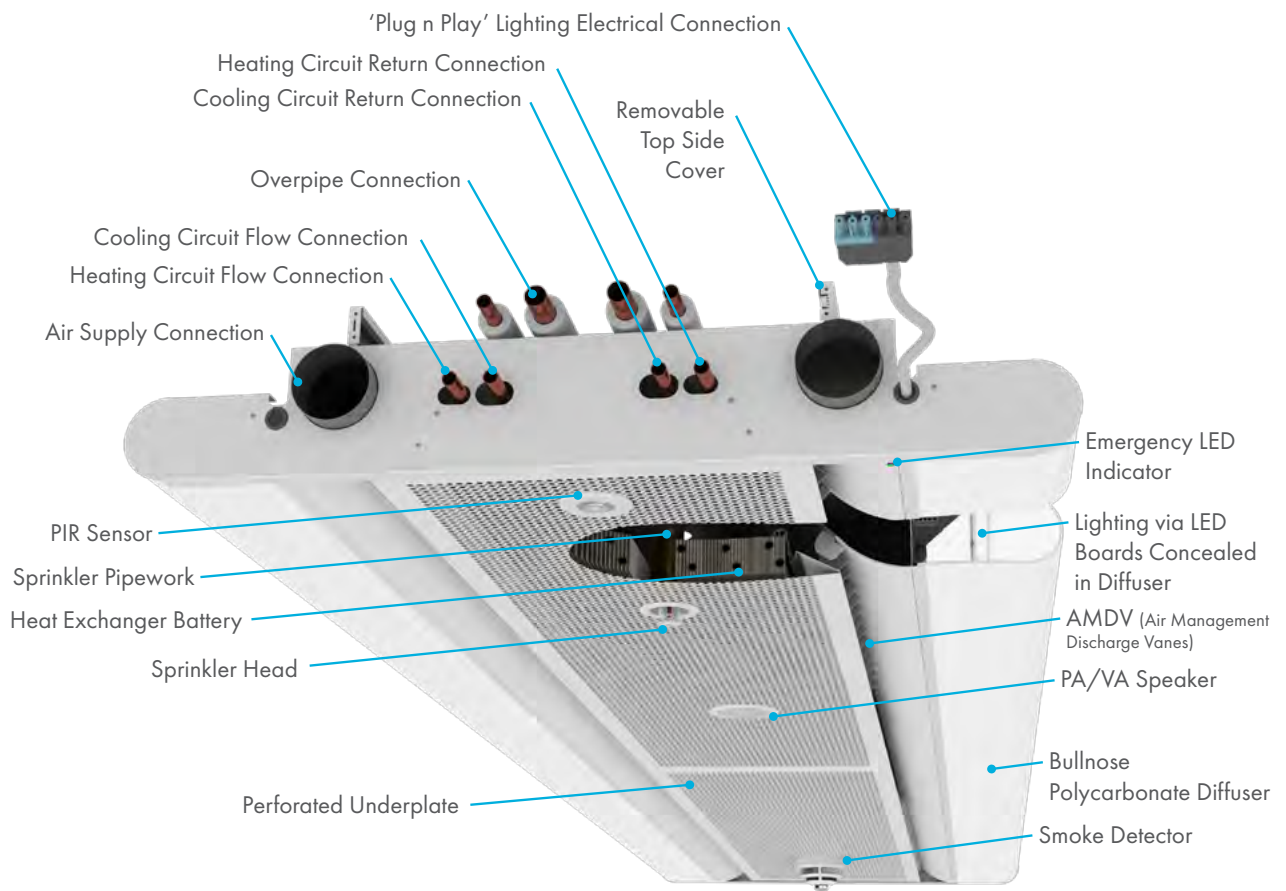

Finish and Appearance

MSCB's offer an alternative to the monolithic ceilings that have become commonplace in office developments, providing attractive yet functional building services installations. The appearance of each beam can be customised in terms of shape, dimensions, lighting options, colour and perforation pattern to meet the client's particular requirements.

We have a wide range of extruded aluminium side profiles to facilitate various different types of luminaire. We also have a wide range of extruded polycarbonate (fire rated) side profiles which become the lighting optic. More variants of the various aspects of MSCB's are available upon request and any new design requirements can be accommodated.



MSCB Design Options Examples

- Cooling
- Heating (Active)
- Up-Lighting
- Electrical Compartmentation
- Direct Lighting
- Emergency Lighting
- Control Valves
- Sprinklers
- Acoustic Insulation
- Smoke Detectors
- Lighting Sensors
- Distribution Ductwork
- Fresh Air (Active)
- PA / VA Speakers
- Distribution Water Pipes

Underplate Perforation Examples

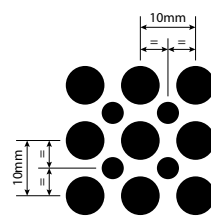

7D Double Dot: 51% OA

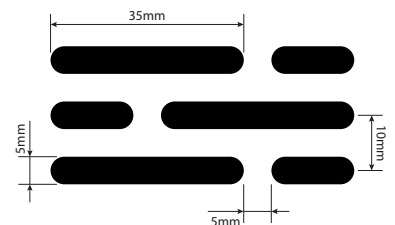

5S Slot: 43% OA

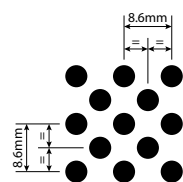

4D: 33% OA

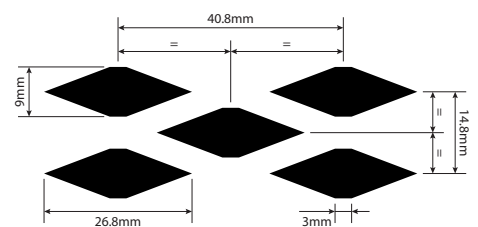

Diamond: 45% OA

Chilled Ceilings - 1st Generation

Introduction & Overview Technical Advancements of Chilled Ceilings

Static cooling systems (chilled ceilings) have, over the past 40 years, proven themselves capable of delivering high levels of occupancy comfort at reduced running costs. **Frenger designed, supplied and installed the “World’s Largest Radiant Chilled Ceiling” system in 1962; the 175,000 square meter, 27 stories high, Shell Oil headquarters, situated on the river Thames in London.** This building was also the first fully sealed air conditioned building in Europe and was revolutionary at its time as this Frenger Chilled Ceiling used the River Thames water to cool the building down. This was achieved by pumping in cool water from upstream to a secondary heat exchanger which in turn cooled (took heat out of the building by “Radiant” absorption) the building down, then depositing the warmer return water from the secondary heat exchanger down stream. This installation operated in excess of 50 years and is a testament to the integrity of the product and to Frenger’s design capabilities.

Since this time the cooling requirements for a typical office environment have increased considerably; higher occupancy densities and a much higher usage of IT equipment have all fuelled this increase. It became apparent in the mid 1990’s that the cooling capacity of a traditional chilled ceiling was not sufficient to meet these increased heat-gains, and consequently higher-capacity Passive Chilled Beam fin coil batteries were introduced into perimeter zones to offset the solar load generated at the building façade.

Although fin coil batteries provided the extra cooling at lower cost in £ / watt than the traditional radiant chilled ceiling, the perimeter aesthetics suffered due to the fin coil batteries requiring large size perforations and percentage open area to allow air (“convection”) to circulate and this also reduced occupancy comfort, due to higher air velocities.

Frenger however saw the opportunity to take all the benefits from a traditional Radiant Chilled Ceiling for radiant cooling, and to develop a “hybrid” product solution that also has the cooling performance of convective only passive beams. The hybrid retained a 40% “Radiant cooling” quotient to yield similar aesthetics as associated with the traditional Radiant Chilled Ceilings, also with low air velocities (for compliance to ISO 7730 European Standard for “Indoor Air Comfort Conditions”) and a 60% convection element for high output cooling. Frenger’s “hybrid” Radiant / Convective Chilled Beams are detailed on pages 10 and 11.

These attractive high quality ceiling systems provide the best in occupancy comfort given their high “Radiant” quotient. **Approximately 70% of the total cooling is by radiant absorption and the remaining 30% by convection if the back of the tiles are insulated,** and circa 55% Radiation and 45% Convection if the cooling tiles are un-insulated.



Shell Oil HQ, River Thames

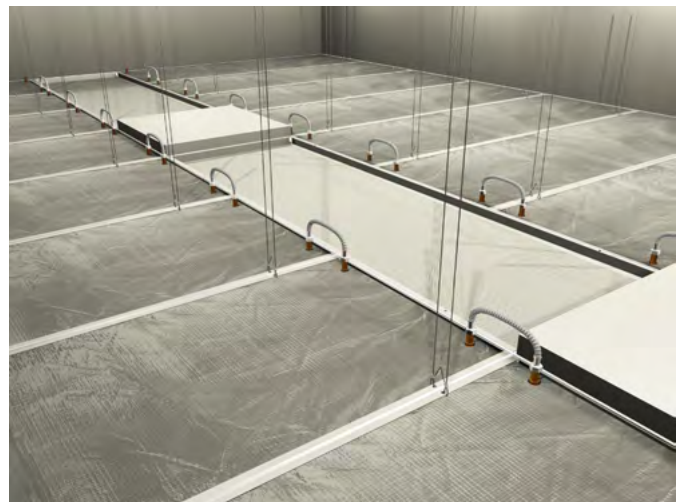

Traditional Radiant Chilled Ceiling



“Hybrid” Radiant / Convective Chilled Beam Ceiling

The cooling tiles are constructed from zinc coated steel which is polyester powder coated to whatever the project colour requirements are.

Aluminium extruded heat exchange “pipesats” are powder coated black and are bonded to the back of the perforated metal tile. The tiles can be any size and as large as 1.35m x 1.35m, these are known as “Mega Tiles”. The tiles are usually insulated with black tissue faced mineral wool pads with a class ‘O’ foil backing for increased “Radiant” component (70% Radiation / 30% Convection).

Typically the cooling effect is 80W / m² of activated chilled ceiling tiles if insulated and 90W / m² of activated chilled ceiling tiles is possible if the ceiling tiles are un-insulated, however the Radiant component reduces to approximately 55% and the rest of the cooling is by 45% convection-element when the tiles are un-insulated.

The above listed cooling effects are based on 8.5°C difference between “mean water temperature” (MWT) and the “design room temperature”, known as dT(k).

Ordinarily, the ceiling grid (Tartan Grid as shown in the picture above right) can represent circa 20% of the overall ceiling if the grid was 1.5m x 1.5m and each plain grid was 150mm wide. An allowance of approximately 8% of the total ceiling area being taken up by light fittings should also be taken into consideration when calculating the nett cooling effect on the floor area below the traditional type chilled ceiling. The rule of thumb is that circa 72% of the total ceiling area (room size) is to be activated by cooling coils. **As such 80 watts / m² usually nets out at 57.6 watts / m² on the floor (insulated tiles)** and 90 watts / m² nets out at 64.8 watts / m² on the floor (uninsulated tiles) at 8.5 (dTk).

Should more of the ceiling be required to be activated this is usually achieved by the use of lay-in chilled tiles on an exposed grid, as detailed in the picture opposite.

These solutions are both energy efficient and very low maintenance and provide high levels of radiant absorption which is the best form of cooling possible.

Should, however more cooling be required than that of a traditional first generation chilled ceiling then see pages 10 and 11 for Frenger’s hybrid of a Radiant Chilled Ceiling and a Passive Chilled Beam to provide the high cooling duties achieved with Passive Chilled Beams, whilst maintaining a good level of radiant absorption (approximately 40% radiant absorption) for improved occupancy comfort.

With Frenger’s Radiant Chilled Beams the customer has freedom of choice of ceiling aesthetic and construction type and from any ceiling manufacture even with small perforations (2.4mm, 3.0mm) and low percentage open area (28%, 40%) as associated with the traditional contact type radiant chilled ceiling solutions.

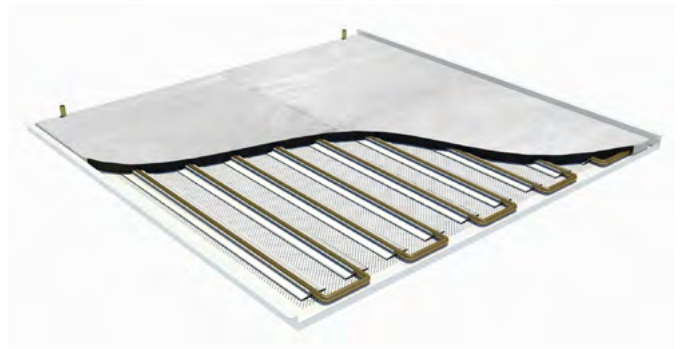

Mega “chilled tile”



Tartan Grid Ceiling



Lay-in “chilled tile”



Exposed grid for lay-in “chilled tiles”

Radiant Heating

Radiant Heating Principles

Radiant Heating is a highly effective method of heating a room. Radiant ceiling panels heat all of the room's surfaces (walls, floor, desks etc...), which in turn heat up the air within the room. Radiant panels also provide heat directly to the occupants. Consequently, radiant heating affords an extremely comfortable indoor environment, where there is little risk of the person feeling too cold under the table or too hot on the head given the surface temperature of the panels. Furthermore, radiant heating focuses on the areas where heating is most required - the coolest items in the room (usually the external walls and windows). Unlike convective heating, an increase in ceiling height does not significantly increase the amount of heat required, hence radiant heat is perfect for large open areas with a lot of air volume.

Radiant ceiling heating systems function in virtually all types of buildings, from busy office environments, large warehouses, large hospitals to small day - care centres. The system can be easily modified to suit changes to the wall or floor layout making it an extremely flexible heating solution.

Key features of high level Radiant Heating

- Good thermal climate.
- Releases valuable floor and wall space.
- Heat goes where it is most needed – reduces the risk of cold draughts.
- Low temperature gradient of the air within the room from floor to ceiling ($0.5^{\circ}\text{C} / \text{m}$ as opposed $2^{\circ}\text{C} / \text{m}$ for fan convective heaters).

Modula

Frenger's Modula radiant panel is a high-performing smooth faced heating unit. Copper pipes are fixed rigidly to the rear of either steel or aluminium panels via extruded aluminium pipe seats for optimum heat transfer. The panel is designed to be free-hanging or integrated into a standard exposed grid ceiling system. Operating weight is a lightweight $21\text{kg} / \text{m}^2$. Panels are backed with 25mm thick foil-backed class 'O' insulation, and are finished polyester powder coat white RAL9010 as standard.

- Modular system.
- Up to 3.0m long as a single unit.
- Up to $588\text{W} / \text{m}^2$ @ 55 dtK room (mwt - room temp).

Modula is particularly suited for use in hospital wards and corridors, school halls, classrooms and offices. In fact anywhere where there is a need for high capacity heating with a lightweight aesthetically-pleasing panel.

Frengerwarm

Frengerwarm is a system of custom made, smooth faced aluminium or steel panels manufactured to any length / width / shape to suit the application. Panels can be wall mounted, free-hanging, surface mounted or recessed into a suspended ceiling system. Copper pipes are fixed rigidly to the rear of the panels via extruded aluminium pipe seats for optimum heat transfer. Panels are backed with 60mm thick foil-backed class 'O' insulation, and are finished polyester powder coat white RAL9010 as standard.

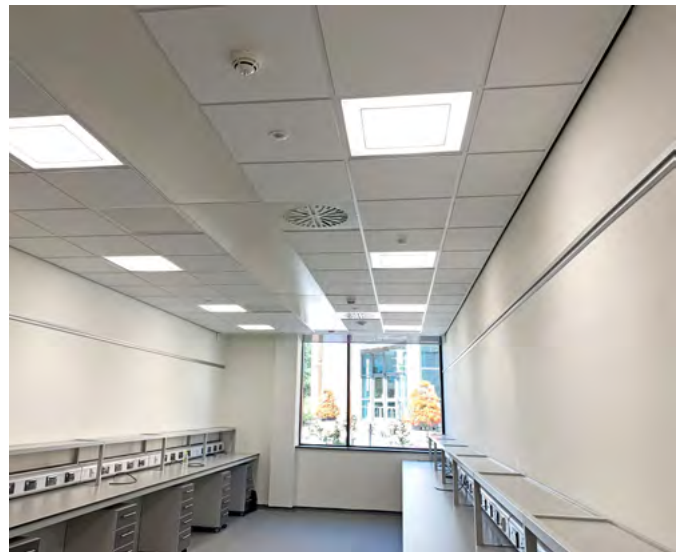
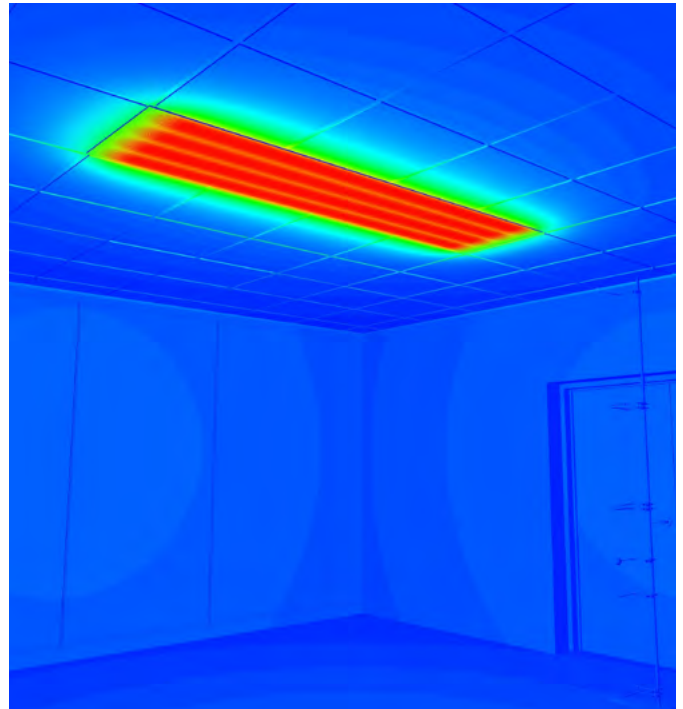

Frengerwarm Cont.

- Modula or perimeter system.
- Can be customised to suit environment.
- Up to 588 W / m² @ 55 dtK room.

Frengerwarm is particularly suited for use in school gymnasiums and classrooms, hospital wards, corridors and offices. Frenger's bespoke manufacturing approach enables us to accommodate most applications, including mitred details and column trimming.

Prison Heating

Frenger's Secure Environment range of anti ligature heating products are designed to provide reliable, efficient and unobtrusive heating within Safer cell, MHU (Mental Health Unit) and other secure environments.

The purpose made UK manufactured product range features three core products that are designed to satisfy the exacting requirements of any secure environment:-

- PCP Frengerwarm Ceiling Panel.
- PNP Frengerwarm Cornice Panel.
- PR Frengerwarm Radiator.

Each Product is designed to operate with LTHW and have been fully performance tested in accordance with the latest appropriate standards (EN14037 / BS EN 442).

All purpose designed systems are constructed from reinforced steel panelling and include secure fixings as standard. The anti-vandal construction also takes account of designing out any ligature points. Each of these product ranges ("PCP", "PNP" and "PR") have been fully destruction tested and are considered by NOMS (National Offenders Management Service) to be fully compliant with the Custodial Property Specification (STD / M / SPEC040) which covers the use of radiant heating panels within Safer Cells.

- Considered as NOMS compliant.
- Purpose made systems can be tailored to suit almost any secure environment.
- Designed to operate with LTHW water supplies.
- Capacities in excess of 350 W / m @ 55.5 dtK room.

EcoStrip XP

EcoStrip XP is an ideal solution for the industrial heating of larger buildings such as aircraft hangars, sports halls and factories. It may be wall mounted or free-hanging and is available in lengths from 4m to 100m. Steel panels pre-fixed to 18mm OD steel pipework grids to create the radiating surface. Panels are available as standard in either RAL9016 (white) or RAL9002 (grey) paint finish.

- Linear product.
- Can be fabricated on site in lengths up to 100m.
- Designed to operate with LTHW, MTHW and HTHW water supplies.
- Up to 761W/m @ 55 dtK.



Prison Panel Radiator

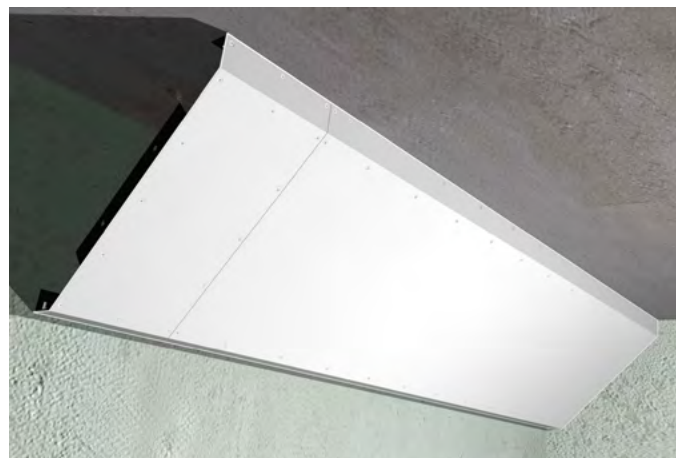

Cornice Prison Panel



Prison Ceiling Panel

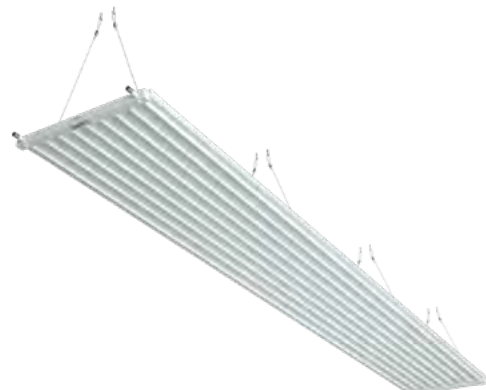

EcoStrip XP Heating Panel

Electric Heating

Air Curtains

Frenger's range of Air Curtains create an air barrier, which helps to prevent cold draughts thus creating a comfortable indoor climate. Energy losses through openings are reduced, which means considerable savings.

When the doors are closed, the Air Curtains will contribute towards the heating around the entrance area if required. The heated air from the air curtains will also help to dry any water / sleet dragged in to an entrance, as such assisting in creating a safer environment.

Although our Air Curtains emit warm air, the main purpose of an Air Curtain is not to provide general heating in a space but to balance temperature differentials and maintain these differentials by using a pressurised stream of air.

Product benefits can be summarised as follows:

- Compact.
- Low noise.
- Suitable for doors of almost any width.
- Suitable for doors heights up to 4m.
- Ambient, electric or water heated designs.

Radiant Heaters

Electric Radiant Heating is a highly effective method of heating a room. Electric Heating Panels heat all of the rooms surfaces (desks, floor, etc.), which in turn heat up the air within a room. Consequently, electric radiant heating panels afford an extremely comfortable indoor environment, where there is little risk of the person feeling too cold under the table or too hot on the head. Furthermore, electric radiant heating focuses on the areas where heating is most required – the coolest items in the room (usually the external walls or windows). Unlike convective heating, an increase in ceiling height does not significantly increase the amount of heating required.

Product benefits can be summarised as follows:

- Immediate heat.
- Discreet.
- Mounting heights up to 40m.
- Recessed mounting option.
- Ceiling mounting option.



Surface Mounted Air Curtain



Recessed Air Curtain

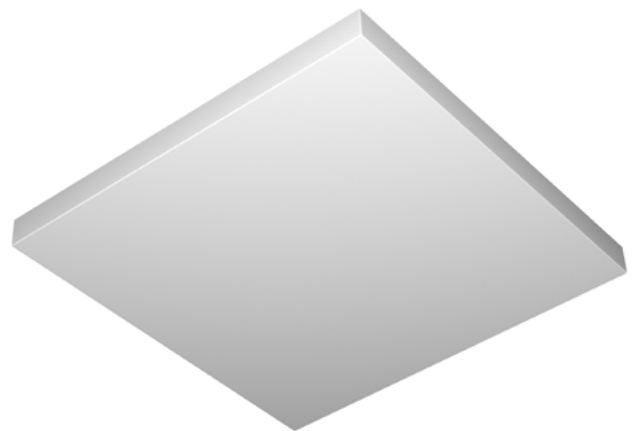

Energocassette Radiant Heater



Energoinfra Radiant Heater



Energostrip Radiant Heater

Recepto™ MVHR Units

Frenger's latest range of HVAC solutions, Mechanical Ventilation Heat Recovery Units (MVHR), are some of the highest efficiency units available on the market. The "Recepto" product range is designed to provide energy savings for a wide variety of applications predominately for Schools, Academies and Universities but also for Offices and Shops. The units transfer heat from extracted room air, via the use of a Eurovent certified Klingenburg aluminium static heat exchanger, to the fresh air supply with an efficiency of up to 94%.

The MVHR units are high-efficiency static exchangers featuring aluminium plates with countercurrent exchange. The achievable efficiency can exceed 90% because they ensure the transfer of countercurrent heat between two air flows with different inlet temperatures. To increase the efficiency of the exchanger, the plate surfaces feature special baffle plates and to lower noise levels the Recepto unit has 45kg/m³ insulation sandwiched between the double skin outer body of the MVHR.

Key Features

- High thermal efficiency (Up to 94%).
- Shallow depth (as little as 344mm deep).
- Low noise levels.
- Double skin fully insulated construction to meet the acoustic requirements of BB93.
- Less than 1% air leakage.
- F7 filters, as standard, to meet air filtration industry guidelines (Building Bulletin 101). All performance data provided includes the use of filters.
- Eurovent certified aluminium heat exchanger.
- Low SFP due to unique fan design.
- Fully compliant with ErP requirements in the Eco Design Directive.
- Freecool setting to allow air to bypass heat exchanger, providing supply air at outside temperature.
- Optional touch screen controller.
- Heating and cooling can be provided with optional accessories.
- Fully reversible handing due to symmetrical configuration. This allows air circuits to be easily inverted to change handing on site (one unit can be either handing).

Construction

The external casing is made from 24mm double skin panels, using galvanised steel sheets pre-insulated with polyurethane foam (density 45 kg/m³). The foam uses a water based foaming agent (GWP-0)

High-efficiency static exchangers feature aluminium plates with countercurrent exchange. The achievable efficiency can exceed 90% because they ensure the transfer of countercurrent heat between two air flows with different inlet temperatures. In order to increase the efficiency of the exchanger, the plate surfaces feature special baffle plates.

The plug-type centrifugal fan for supply and return with an electronically-controlled (EC) permanent magnet synchronous motor, supply voltage 230V 50Hz. The impellers are angle mounted design to ensure minimal noise and optimise airflow with reduced construction depth.

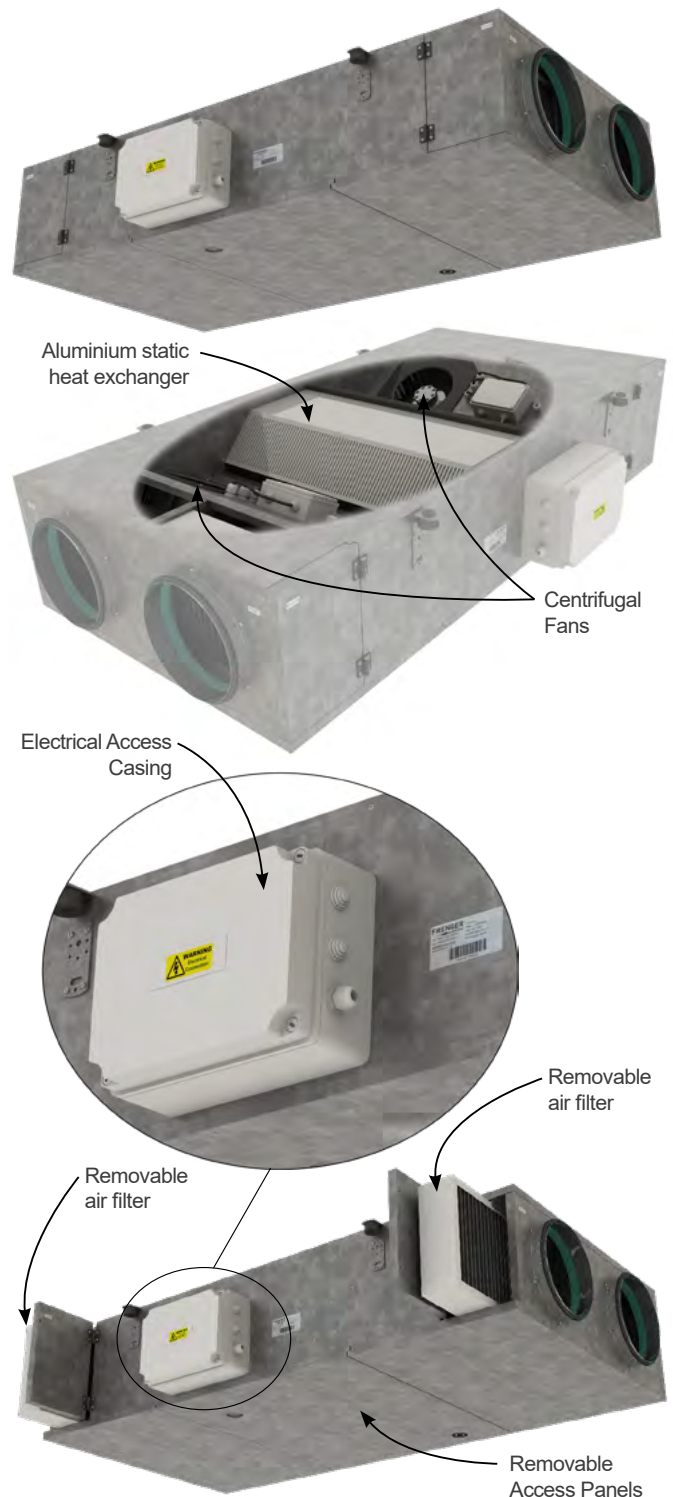

Air intake circuits use F7 (fine filtration efficiency) 98mm thick air filters with pleated microcells and M6 (average) for the exhaust circuit. These are sized to minimise pressure drops and are accessed by openings in the side of the unit. The units are fitted with air pressure switches to indicate when the filters require replacement.

The on-board electrical panel is accessible on the side of the unit. This panel includes the line fuse and electronic power board for the manual or automatic control of the operation of fans and air treatment accessories. The remote control features a display and capacitive-type touch keyboard.

Recepto™ Mini MVHR

Frenger also offer the more compact unit 'Recepto Mini'. At approximately 600mm wide (compared to the 850mm for the narrowest standard Recepto), the Passivhaus certified Recepto Mini is more suited for smaller and more restricted space applications such as office meeting rooms and domestic applications. At just 570mm wide the RM-170 is suitable for fitment into standard 600mm modular kitchen spaces.

All models can be 'Horizontally Mounted' for ceiling applications or 'Vertically Mounted' for wall mounted applications. These mechanical ventilation heat recovery units are highly energy efficient and are able to transfer heat from the extracted room air to the fresh air with an efficiency up to 88%.

The Recepto Mini features easily accessible, highly efficient air filters. The external air intake circuits use F7 (fine filtration) that filters 70% of PM1 (In accordance with ISO 16890), while the room extract circuit uses an M5 (medium filtration) that filters 50% of PM10.

As standard the Recepto Mini comes fitted with a humidity sensor on the extract ducting, this allows for automatic centralised air flow control for the units. They also have an anti freeze cut out to prevent damage to the heat exchanger, which will set the fan speed to minimum if the intake temperature drops below -5°C, and will cut out if the temperature goes below -10°C. The use of an anti freeze heating coil is recommended if the unit is installed in an area with frequently cold weather. They are also available with optional integrated electric heaters to regulate the temperature within safe operating limits and prevent freezing.

The Recepto Mini comes equipped with a touch pad control panel as standard, which facilitates functions such as weekly schedule management, setting air flow modes including; manual mode, automatic mode, party mode and holiday mode.

The units are also fitted with a bypass double damper which disables the heat exchanger to automatically allow for 100% free-cooling or free-heating.



RM-170 Horizontal Orientation



RM-270 Horizontal Orientation



RM-170 Vertical Orientation

RM-270 Vertical Orientation



Multi-Service Radiant Panels

Frenger's Acoustic Lighting and Heating Rafts, otherwise known as Multi Service Radiant Panels (MSRP's) consist essentially of a free hanging radiant heating panel coupled with other services such as:

- Lighting.
- Acoustic Sound absorbing materials.
- Apertures for sprinkler heads.
- Compartment trunking for other electrical services.
- Apertures for PA and VA speakers.
- Lighting Control, PIR and Photocells.

Radiant Heating

The radiant heating element is the same technology as utilised for Frenger's tried and tested Modula panels.

The panel is constructed from zinc coated steel which is perforated and folded to the project specific requirements before being polyester powder coat finished to any RAL colour as required, (RAL 9010 is standard).

The panel utilises Frenger's optimised extruded aluminium heat exchanges and seamless copper tube heating elements.

Lighting

Virtually any type of lighting solution can be accommodated by Frenger's MSRP and all lighting is manufactured in house and bespoke to the project solution. Direct only, indirect only, combination of direct and indirect lighting from either the same light source or different sources can be accommodated.

T5 florescent or LED light sources, aluminium louvres, micro lens optics, opal acrylic or even extruded acrylics for continuous / seamless lighting can be accommodated.

All lighting is designed in house using lighting software design packages and the prototyped and photometered in Frenger's in house Photometric Laboratory and Integration Chamber for L.O.R (Light Output Ratios). Frenger convert to Lumdat files and produce lighting calculations for the space requirement using Relux / Dilux for compliance to CIBSE Lighting Guides LG3 / 7.

Acoustic Sound Absorbing Materials

The perforated areas of the radiant panel are covered with black tissue faced insulating material with a foil backing effectively sandwiched in the middle of two layers of acoustic insulating material, the top layer of which has black tissue acoustic material face upwards.

Frenger's have their own in house sound laboratory and also make use of third party acoustic testing for verifications.

Note: Acoustic Absorption Area (m²) figures detailed below are per linear m of MSRP, hence the absorption area's should be multiplied by the chosen MSRP length. Data based upon independent testing conducted by SRL (Sound Research Laboratories) Ref. C/21760/R01 to BS EN ISO 354:2000.

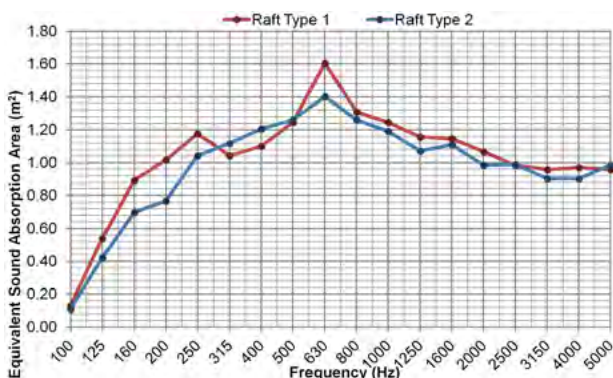

Raft Type 1 - Central LED Lighting



Raft Type 2 - Louvre Lighting

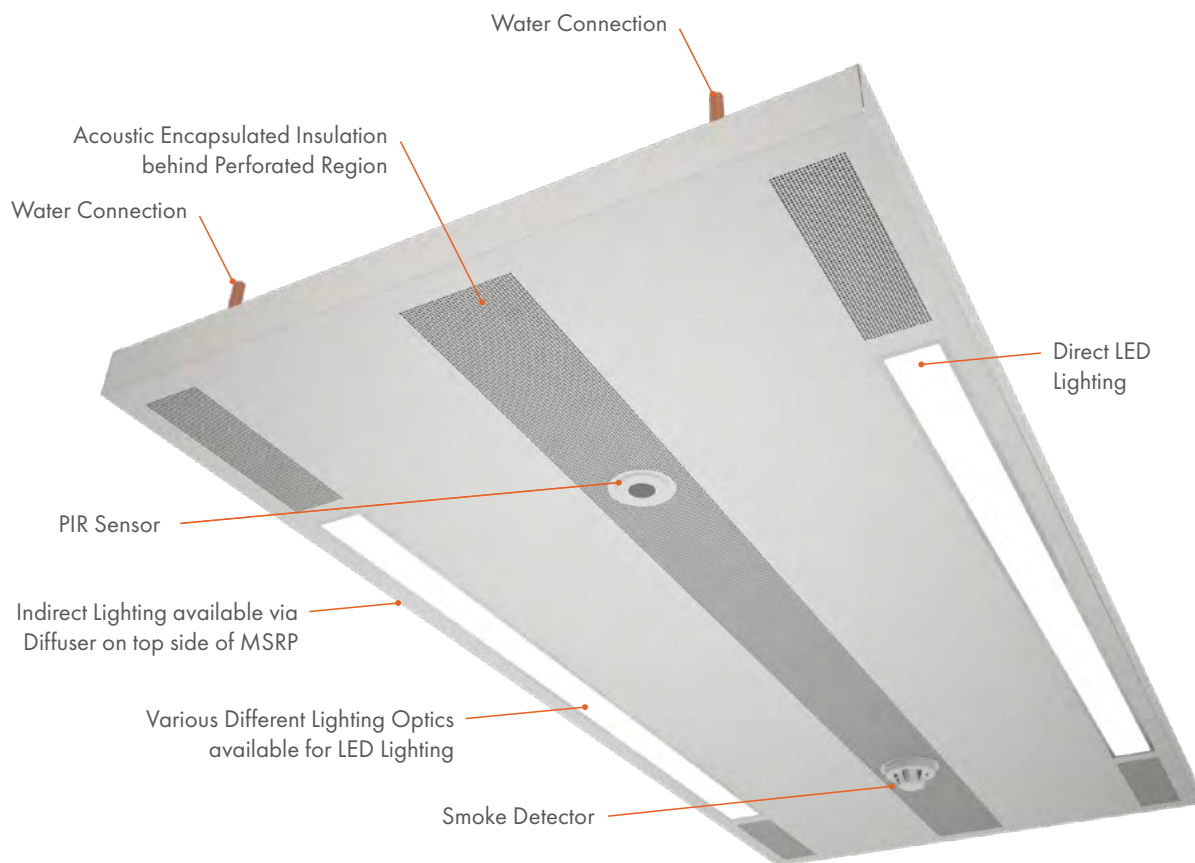

Finish and Appearance

Frenger's Acoustic, Lighting and Heating Rafts, otherwise known as Multi-Service Radiant Panels (MSRP's) are a free hanging radiant heating panel which may also have options of lighting and/or acoustic sound absorbing properties. An ideal solution for schools, academies, youth centres and universities, other services can also be incorporated such as apertures for sprinkler heads, compartment trunking for other electrical services, apertures for PA and VA speakers plus lighting control, PIR, Photocells and other building services which are 100% pre-fabricated off site in Frenger's controlled factory.

MSRP Design Options Examples

- Heating (Active)
- LED Up-Lighting
- Direct LED Lighting
- Emergency LED Lighting
- Acoustic Insulation
- Electrical Compartmentation
- Control Valves
- Sprinklers
- Smoke Detector
- Lighting Sensors
- PA / VA Speakers
- Distribution Water Pipes

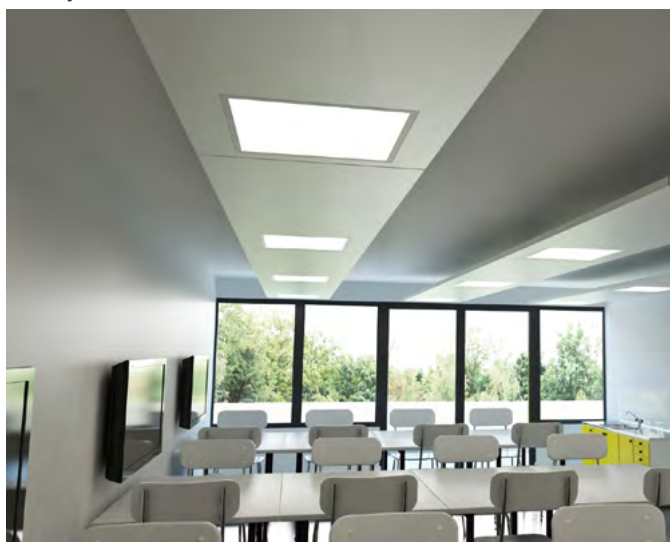

MSRP Example with 600x600 Square LED Lighting



MSRP Example with Acrylic Diffuser LED Lighting and Acoustic Insulation

Large Project Experience

55 Baker Street



The iconic 55 Baker Street building in London has been completely refurbished and redeveloped by London & Regional. The project's well-regarded success proves that 21st Century design can be applied just as well to existing buildings as it can to new buildings.

Frenger's order value was £7.6 million for the Supply and Installation of 4,500 Active Multi-Service Chilled Beams (this equates to in excess of 11km of Multi-Service Chilled Beams). The total refurbishment costs for this project were in the region of £200 million for HBG Construction (BAM) and this is still the world's largest MSCB project to date.

Frenger designed, developed and in-house Climatic tested the MSCB solution at the Derby facility to validate cooling and heating performance compliance to BS EN ISO 7730 for room occupancy comfort.

The International House



Frenger supplied the International House in Sydney with X-Wing Radiant Passive Chilled Beams. Constructed with CLT (Cross Laminated Timber), International House won copious awards including the Development Excellence award for Sustainable Development from Urban Taskforce Australia.

The project set a new benchmark for commercial building typologies, incorporating comprehensive and varied environmental sustainable design initiatives throughout. International House, Sydney is a 6 Star Green Star building which incorporates Frenger's X-Wing Radiant Passive Chilled Beams in place of conventional air conditioning to deliver indoor cooling whilst maintaining high thermal comfort levels on the commercial floor plates.

Lambeth Civic Centre



Lambeth Civic Centre is a £45 million, 6 story building in heart of Lambeth. The building is constructed with a six-storey, post-tensioned concrete frame, which sits on 195 rotary piles. In order to attain a BREEAM Excellent rating a number of energy efficient systems have been utilised, such as Frenger Active and Passive Multi Service Chilled Beams and Active Ceiling Integrated Chilled Beams, with and an electronically charged intelligent glazing that provides solar control.

The project had limited space/locations for the service risers and bulkheads. To achieve adequate distribution of fresh air over the floor space, the design team and Frenger utilised long runs of Multi-Service Chilled Beams (MSCB's) with the fresh air connected in series, this effectively made the MSCB's air chambers the distribution ductwork, which not only saved on ductwork but also provided superior aesthetics.

Because the long MSCB runs serve large open areas, the Chilled Beams had to be designed to accommodate higher than normal fresh air volumes of up to 150 l/s per MSCB run. Given that the project didn't have enough space, or the available budget for the individual dampers to be fitted between individual MSCB's, Frenger utilised its unique patent protected Burst Nozzle design to ensure that each MSCB was able to deliver the correct fresh air volumes for each specific control zone (based on 12 l/s/person with 1 person per 10m²) based upon the available upstream static pressure. Given the high air volumes, Frenger also completed noise level testing within its Hemi-Anechoic Acoustic Testing Laboratory, to ensure the MSCB's didn't generate excessive noise.

Project References

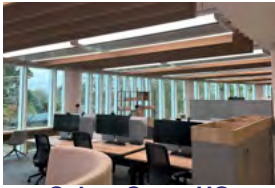

Spirax-Sarco HQ
Cheltenham, UK - 2024
Active Multiservice



Ashburton Civic Centre
Ashburton, NZ - 2023
Active Chilled Beams



Aston Martin F1 HQ
Silverstone, UK - 2022
Active Multiservice

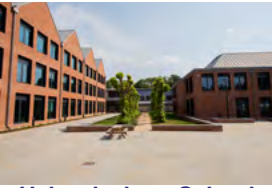

Haberdashers School
Elstree, UK - 2022
Multiservice Radiant Panel



20 Finsbury
London, UK - 2022
Active Multiservice



LSTM
London, UK - 2022
Active Chilled Beams



Dogger Bank Wind Farm
Port of Tyne, UK - 2022
Active Multiservice



Hub on Causeway
Boston, US - 2022
Active Chilled Beams



Victorian Heart Hospital
Melbourne, AUS - 2021
Active Chilled Beams



183 - 185 Clarence Street
Sydney, AUS - 2020
Active & Passive Chilled Beams



Riverside House
Salford, UK - 2019
Passive Chilled Beams



Three Haddington Buildings
Dublin, Ireland - 2019
Active Multiservice



NTU Engineering
Nottingham, UK - 2019
Multiservice Radiant Panels



Qatar Airways
London, UK - 2018
Active Multiservice



Ofcom Riverside House
London, UK - 2018
Passive Multiservice



UW Life Sciences
Seattle, USA - 2017
Passive Chilled Beams



Red Cross
Perth, Australia - 2017
Active Multiservice



Brunel University
London, UK - 2017
Active & Passive Chilled Beams



ASOS Leavesden
Watford, UK - 2017
Active Chilled Beams



90 Bartholomew Close
London, UK - 2017
Active Multiservice



Lambeth Civic Centre
London, UK - 2017
Active & Passive Multiservice



Queen's University
Belfast, UK - 2016
Passive Multiservice



SAE Qantm
Sydney, Australia - 2016
Passive Chilled Beams



93 Farringdon Road
London, UK - 2016
Active Multiservice



20 Eastbourne Terrace
London, UK - 2016
Active Multiservice



Building R7, King Cross
London, UK - 2016
Active Multiservice



KHUH, Oncology Centre
Bahrain - 2016
Active Chilled Beams



Sensor City
Liverpool, UK - 2016
Active Multiservice



Barangaroo C2
Sydney, Australia - 2016
Passive Chilled Beams



National Film & TV School
Beaconsfield, UK - 2016
Active Multiservice / Active Chilled Beams



South Bucks Hospice
High Wycombe, UK - 2016
Active Chilled Beams



Uni of Canterbury
New Zealand - 2016
Active Chilled Beams



Newcastle Civic Centre
Newcastle, UK - 2016
Active Chilled Beams



Skyline Hills Library
San Diego, USA - 2016
Active Chilled Beams



Skywalk
Anchorage, USA - 2015
Active Multiservice



Ocean City School
New Jersey, USA - 2015
Active Chilled Beams



Gatwick Airport
Gatwick, UK - 2015
Passive Chilled Beams



Queens University
Belfast, UK - 2015
Passive Chilled Beams



Sports Direct Head Office
Derby, UK - 2015
Active Chilled Beams



Great Ormond Street Hospital
London, UK - 2015
Active Chilled Beams



Charles Street, Sheffield University
Sheffield, UK - 2015
Passive Chilled Beams



Monash Children's Hospital
Australia - 2014
Active Chilled Beams



Alder Hay Research & Education
Liverpool, UK - 2014
Active Chilled Beams



High Holborn
London, UK - 2014
Active Multiservice / Active Chilled Beams



Northbrook College
Worthing, UK - 2014
Active Multiservice



50 Flinders Street
Adelaide, Australia - 2014
Passive Chilled Beams



Arena Birmingham
Birmingham, UK - 2014
Passive Chilled Beams



Northwick Park Hospital
Harrow, UK - 2014
Active Chilled Beams



West Suffolk House
Ipswich, UK - 2014
Passive Chilled Beams



240 Blackfriars Road
London, UK - 2014
Active Chilled Beams



West Yorkshire Police
Wakefield, UK - 2014
Passive Chilled Beams



18-20 Grosvenor Street
London, UK - 2014
Active Chilled Beams



Great West House
London, UK - 2013/14
Active Multiservice



1 Canberra Avenue
Australia - 2013
Passive Chilled Beams



SIEC Tonsley House
Australia - 2013
Active & Passive Chilled Beams



ANU
Australia - 2013
Active Chilled Beams



Anglia Ruskin University
Cambridge, UK - 2013
Passive Multiservice



IMAS Hobart
Australia - 2012
Passive Chilled Beams



Beaufort House
London, UK - 2012
Active Multiservice



Neo Bankside
London, UK - 2012
Active Multiservice



5 Murray Rose Avenue
Sydney, Australia - 2012
Passive Chilled Beams



Exeter University
Exeter, UK - 2012
Active Chilled Beams



Stafford College
Stafford, UK - 2012
Active Chilled Beams



Wyre Forest
Kidderminster, UK - 2012
Active Multiservice



Trinity Grammar
Australia - 2012
Passive Chilled Beams



Cambridge Metallurgy
Cambridge, UK - 2012
Passive Chilled Beams



Tate Modern
London, UK - 2012
Passive Chilled Beams



65 Southwark Street
London, UK - 2012
Active Multiservice



700 Bourke Street
Australia - 2012
Passive Chilled Beams



Veolia Environmental
Cannock, UK - 2012
Passive Chilled Beams



Grosvenor Hill
London, UK - 2012
Passive Multiservice



CISCO
Reading, UK - 2012
Active Multiservice



Langley Point
Birmingham, UK - 2012
Passive Chilled Beams



Common Wealth Bank
Australia, Sydney - 2012
Passive Chilled Beams



Southampton Civic Centre
Southampton UK - 2011
Active Multiservice



Trinidad School
Trinidad & Tobago - 2011
Passive Chilled Beams



Domino's Pizza HQ
Milton Keynes, UK - 2011
Passive Multiservice



Eskom, Megawatt Park
South Africa - 2011
Passive Chilled Beams



Vodafone Innovation
South Africa - 2011
Passive Chilled Beams



World Park
Adelaide, Australia - 2011
Passive Chilled Beams



Walthamstow Station
Walthamstow, UK - 2011
Passive Chilled Beams



King Saud Bin Abdul
Saudi Arabia - 2011
Active Chilled Beams



Gatwick Search Area
London, UK - 2011
Passive Chilled Beams



All Saints Academy
Cheltenham, UK - 2011
Passive Chilled Beams



24 Britton Street
London, UK - 2011
Passive Multiservice



University of Botswana
Botswana - 2011
Active Chilled Beams



Royal London Hospital
London, UK - 2011
Active Multiservice



City Centre Tower 8
Australia - 2011
Passive Chilled Beams



Wollongong University
NSW, Australia - 2011
Passive Chilled Beams



Melbourne University
Australia - 2010
Active Chilled Beams



Walsall Hospital
Walsall, UK - 2010
Active Chilled Beams



Macmillan Renton Unit
Hereford, UK - 2010
Active Chilled Beams



Kangan Batman Tafe
Australia - 2010
Active & Passive Chilled Beams



HML Headquarters
Skipton, UK - 2010
Active Multiservice



123 Albert Street
Brisbane, Australia - 2010
Passive Chilled Beams



500 Collins Street
Australia - 2010
Active Multiservice



Google Headoffice
Sydney, Australia - 2010
Passive Chilled Beams



Royal Hobart Hospital
Hobart, Tasmania - 2010
Active Chilled Beams



RMIT 9
Australia - 2010
Active Chilled Beams



Belconnen Police
Australia - 2010
Passive Chilled Beams



Five Rivers
Trinidad - 2010
Passive Chilled Beams



Good Hope Hospital
Sutton, UK - 2010
Active Chilled Beams



1 Lancaster Circus
Birmingham, UK - 2010
Passive Multiservice



Kingswood Lakeside
Cannock, UK - 2010
Passive Chilled Beams



Meridian Court
Edinburgh, UK - 2010
Active Chilled Beams



Sudima Hotel
New Zealand - 2010
Active Chilled Beams



New Scotland Yard
London, UK - 2010
Passive Chilled Beams



CIT
Canberra, Australia - 2010
Active Multiservice



Telcom Square
New Zealand - 2010
Passive Chilled Beams



Anglia University
Cambridge, UK - 2010
Passive Multiservice



Liverpool College
Liverpool, UK - 2010
Active Chilled Beams



Knightsbridge Hotel
London, UK - 2010
Passive Chilled Beams



Loxford School
London, UK - 2009
Active Chilled Beams



Cheshire Police
Cheshire, UK - 2009
Active Chilled Beams



New Cavendish Street
London, UK - 2009
Active Multiservice



Transport House
Sydney, Australia - 2009
Active Multiservice



Civic Offices
Southampton, UK - 2009
Active Chilled Beams



Kingston Aged Care
Australia - 2009
Active Chilled Beams



Monash University
Australia - 2009
Active Chilled Beams



Warnambool Hospital
Australia - 2009
Active Chilled Beams

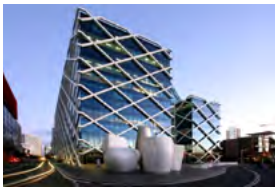

1 Shelly Street
Sydney, Australia - 2009
Passive Chilled Beams



South Australia Police
Adelaide, Australia - 2009
Passive Chilled Beams



Kings College
London, UK - 2009
Passive Chilled Beams



Batman Street
Australia - 2009
Passive Chilled Beams



St Barts Hospital
London, UK - 2009
Active Chilled Beams



Edmund Barton
Canberra, Australia - 2009
Active Chilled Beams



ACAD Hospitals - Stobhill
Glasgow, UK - 2008
Active Chilled Beams



King Street Wharf
Australia - 2008
Passive Chilled Beams



55 Baker Street
London, UK - 2008
Active Multiservice



Sydney Water House
Australia - 2008
Passive Chilled Beams



Wrexham A&E
Wrexham, UK - 2008
Active Chilled Beams



Coventry University
Coventry, UK - 2008
Active Chilled Beams



Gatwick Terminal
London, UK - 2008
Passive Chilled Beams



Suffolk County Council
Suffolk, UK - 2008
Passive Chilled Beams



Bidborough House
London, UK - 2008
Active Chilled Beams



Hallward Library
Nottingham, UK - 2008
Active Multiservice



One East Melbourne
Victoria, Australia - 2008
Passive Chilled Beams



Kings Cross
London, UK - 2008
Active Chilled Beams



Cambridge Library
Cambridge, UK - 2008
Active Chilled Beams



QMC Hospital
Nottingham, UK - 2008
Active Chilled Beams



GRI Gynae
Glasgow, UK - 2008
Active Chilled Beams



Business Centre
Liverpool, UK - 2008
Active Chilled Beams



Wesley House
Brisbane, Australia - 2008
Passive Chilled Beams



64 Allara Street
Australia - 2007
Passive Chilled Beams



Sydney Olympic Park
Sydney, Australia - 2007
Passive Chilled Beams



Duke Street
London, UK - 2007
Active Multiservice



University of Sydney
Sydney, Australia - 2007
Passive Chilled Beams



413 George Street
Sydney, Australia - 2007
Passive Chilled Beams



Hills Science Park
Malvern, UK - 2006
Active Chilled Beams



London Circuit
Canberra, Australia - 2006
Passive Chilled Beams



Edinburgh Council
Edinburgh, UK - 2006
Passive Multiservice



National Farmers Union
Warwickshire, UK - 2006
Passive Multiservice



Project Vauxhall
UK - 2006
Passive Chilled Beams



Parramatta Justice
Sydney, Australia - 2006
Passive Chilled Beams



National Audit Office
London, UK - 2005
Active Multiservice



500 Collins Street
Australia - 2005
Active Multiservice



City Central Tower
Adelaide, Australia - 2005
Passive Chilled Beams



Merck Sharp & Dohme
London, UK - 2004
Active Multiservice



10 Green Coat Place
London, UK - 2004
Active Multiservice



Saffron Hill
London, UK - 2004
Active Multiservice



Experian
Nottingham, UK - 2004
Passive Multiservice



Woolworth House
London, UK - 2003
Active Multiservice



The Bond
Australia - 2003
Passive Chilled Beams



BT Leavesden
Watford, UK - 2002
Passive Chilled Beams



Ealing Studios
London, UK - 2002
Passive Multiservice



Royal Sussex Hospital
Brighton, UK - 2002
Active Chilled Beams



Vodafone
London, UK - 2001
Passive Chilled Beams



Gordon House
London, UK - 2001
Active Multiservice



British Gas
Manchester, UK - 2000
Active Chilled Beams



BT Nottingham
Nottingham, UK - 1998
Passive Chilled Beams

Industry Associations

Always mindful of its place within the HEVAC industry, Frenger Systems pride themselves on broad range of trade associations and accreditations. With a clear service, product and environmental ethos across everything they do, Frenger is focused on meeting and consistently surpassing the expectations of its customers. Frenger invest heavily in achieving industry recognised accreditations and as part of ongoing commitment to their customers and continually assess the level of services they provide. Opening up their company to these independent organisations allows them to continually improve our customer service and satisfaction.

As an engaged member of the HEVAC industry, Frenger are actively asked to participate in industry specific discussions and studies. With this in mind Frenger are proud to have achieved and be linked with the following associations:



BSI EN ISO 9001:2015

Frenger Systems are registered by BSI for operating a Quality Management System which complies with the requirements of BS EN 9001:2015.



Eurovent

Frenger Systems participate in the EC programme for Chilled Beams. Check ongoing validity of certificate: www.eurovent-certification.com or www.certiflash.com Certiflash



Chilled Beam and Ceiling Association

The Chilled Beam and Ceiling Association has been formed by leading companies within the construction industry. The objective of the Association is to promote the use of Chilled Beams and Chilled Ceilings, and encourage best practice in their development and application.



HEVAC Member

HEVAC is the heating and ventilating contractors association. As a HEVAC member Frenger Systems are subject to regular, third party inspection and assessment to ensure their technical and commercial competence.



Federation of Environment Trade Association

The Federation of Environment Trade Association (FETA), of which Frenger Systems is a member of, is the recognised UK body which represents the interests of manufacturers, suppliers, installers and contractors within the heat pump, controls, ventilating, refrigeration & air conditioning industry.



UK Trade & Investment

Frenger Systems are members of both the UK TI (the former Department of Trade and Industry) as well as the Chamber of Commerce for Export Documentation.



Certified CIBSE CPD

Frenger Systems is a CIBSE approved "Continued Professional Development" (CPD) provider. Frenger offers 1 hour lunch time CPD presentations regarding "Chilled Beam Technology", CPD presentations are usually held at Consulting Engineers local practices with lunch provided courtesy of Frenger. Alternatively half or full day Chilled Beam Technology training is available at Frenger's UK Technical Academy in a dedicated training theatre with fully operational BMS system with various different Chilled Beam and Ceiling solutions integrated.

Booking of a CPD Presentation can be requested on Frenger's home page, under the drop down menu headed "Company", then "CPD Booking". Alternatively email sales@frenger.co.uk.

Global Offices



UK Head Office

Frenger System Ltd
Riverside Road
Pride Park
Derby
DE24 8HY

tel: +44 (0) 1332 295 678
sales@frenger.co.uk
www.frenger.co.uk



Australian Office

Frenger
Level 20
Tower 2
201 Sussex Street
Sydney
NSW 2000
Australia

tel: +61 02 9006 1147
sales@frenger.com.au
www.frenger.com.au



American Office

FTF Group Climate
Bryant Park
104 W40th Street
Suite 400 & 500
New York
NY 10018
United States of America

tel: +00 1 (646) 571-2151
sales@ftfgroup.us
www.ftfgroup.us



Agents and Distributors

Frenger has representatives in many countries via business partners and local agents.



UK Head Office

Frenger System Ltd
Riverside Road
Pride Park
Derby
DE24 8HY

tel: +44 0 1332 295 678
sales@frenger.co.uk
www.frenger.co.uk

Australian Office

Frenger
Level 20
Tower 2
201 Sussex Street
Sydney
NSW 2000
Australia

tel: +61 2 9006 1147
sales@frenger.com.au
www.frenger.com.au

American Office

FTF Group Climate
Bryant Park
104 W40th Street
Suite 400 & 500
New York
NY 10018
United States of America

tel: +1 (646) 571-2151
sales@ftfgroup.us
www.ftfgroup.us

Accreditations



Frenger is an FTF Group Company
Registered No. 646 6229 20

www.frenger.co.uk