

the future of space conditioning

EFW - Electric Frengerwarm™

Radiant Heating Panel

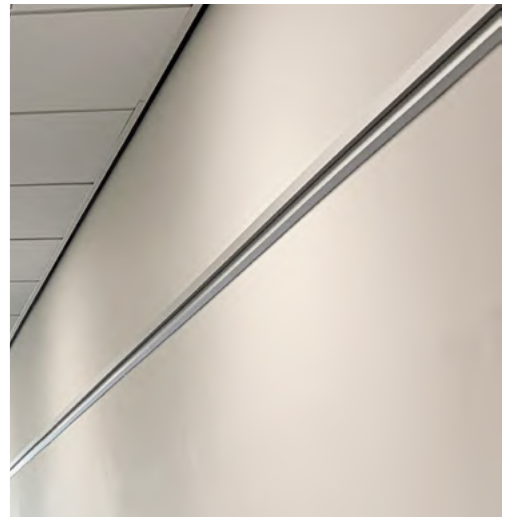

100% Tested and Independently Certified

Electrical Safety

EN 60335-2-30:2009 + A1/11
EN 60335-1:2012 + A11/13/1/14/2/15

Ingress Protection

EN 60529: 1992 + A2:2013 (IP55 & IP56)

Electromagnetic Compatibility

EN 55014-1: 2021
EN 55014-2: 2015
EN 61000-3-2: 2019
EN 61000-3-3: 2013 +A2: 2021

Evaluation of Magnetic Fields

EN 62233: 2008

www.frenger.co.uk
an FTF Group Company

FRENGER[®]
systems

Products You Can Trust



Contents

Introduction	3
Design	4
Installation	5
Installation Examples	6
Installation Arrangement	6
Product Dimensions	6
Minimum Mounting Details	7
Model References	7
Controls	8
Product Testing	9
Product Testing	10
Bespoke Manufacturing	11
Project Specific Testing Facility	12
Photometric Testing Facility	13
Acoustic Testing Facility	14
Industry Associations	15

Introduction

What is Radiant Heating

Radiant Heating is a form of heat transfer. Radiant Heating Panels emit most of their heat via longwave infrared radiation as opposed to convection or conduction. The longwave radiation that is emitted from the Radiant Heating Panels travels through the air (without directly heating the air) to its surroundings of a lower temperature (such as walls, floors, desks and occupants) thus raising the temperature of these surroundings. A secondary effect of the longwave radiation being emitted from the Radiant Heating Panels is that the air is heated by being in contact with the warmer surfaces.

Most radiant heating solutions achieve approximately 70% of the total heating via radiant exchange and 30% via convection. In general, you can have an air room temperature circa 2 deg C lower than the perceived room temperature as the occupants are also heated via the long wave infrared radiation.

How does a Radiant Heating system work

A Radiant Heating System emits heat similarly to that of the sunshine. If you were to stand outside on a hot summers day then you would feel warm and comfortable as the Radiant Heat from the sunshine is travelling through the air and warming your body temperature. However, if a cloud were to prevent the sunshine from reaching you then you would immediately feel colder, even though the air temperature hasn't changed, this is because the cloud is preventing the Radiant Heat from reaching your body.

This works the same way if you think about a Radiant Heating System in an office environment. The Radiant Heat that is being emitted from the Radiant Heating System travels through the air and heats up its surroundings of a lower temperature.

The surfaces of the radiant heating panel have the ability to emit radiation. The ability to emit radiation is measured as an epsilon value, whereby 1.0 is the highest possible and 0.001 the lowest. Typically, unpainted aluminium has an epsilon value of 0.2 and matt white painted metal 0.95 and matt black painted metal 0.97. The surface area and surface temperature are also critically important.

Radiant Equation:

Surface Area x Surface Temperature x 5.67 x epsilon value

Note: 5.67 is a constant value, known as the Stephan Boltzmann constant.

Radiant Heating is by omitting heat energy, whereby the highest temperature interacts with opposing surfaces of a lower temperature, giving its higher energy to the surface with the lower energy to try to become in equilibrium.

Is Radiant Heat expensive to run

As illustrated in 'How does a Radiant Heating system work?' demonstrates that Radiant Heat is fairly instantaneous and as such is an ideal solution for heating large open spaces such as Sports Halls and other environments where you want to heat the occupants quickly without having the heat all the air first. Because Radiant Heating systems don't have to heat up the air first, it means that it drastically reduces energy usage and therefore can save you money.

This principle also applies to Office Developments, Hospitals, Schools, Universities, and Airports, hence why Radiant Heating is a popular solution for heating large commercial buildings.

EFW Electric Heating Panel



Description

Electric Frengerwarm (EFW) is an unobtrusive radiant heating panel. The panels are manufactured from 1.0mm thick steel with a pre painted tough Precoat finish, equivalent to RAL 9016 (White) as standard, other RAL colours available on request. These panels are designed to be integrated within a standard 24mm exposed grid ceiling system.

The electric version of the Frengerwarm radiant heating panel supplies gentle, even, and comfortable heat in various applications. The heaters can be used to provide general heating, or to raise temperature in certain areas (spot heating).

As the EFW electric panel uses radiant heat, which is concentrated in the occupied area thus minimising energy losses through stratification of heated air.

The EFW electric panels have been specifically developed for use in schools and healthcare environments where a smooth faced simple-to-install panel with high heating capacity is the preferred solution.

Standard Features

- Modular system to fit into 600mm exposed grid ceiling.
- Modular lengths; 0.6m, 1.2m, 1.8m, 2.4m, 3.0m.
- Modular widths; 0.3m, 0.6m, 0.9m
- Panel depth 45mm.
- Smooth faced, unobtrusive design.
- Pre coat finished White, equivalent to RAL 9016 20% gloss ($\pm 5\%$).

weight: less than 15.5 kg / m²

Maintenance

The unit has no moving parts, and therefore maintenance requirement is limited to periodic cleaning of the surface of the panel using warm water applied with a soft cloth then wiped dry.

Installation

Standard fixing arrangement from the structural soffit using rigid threaded rod (supplied by others) or suitable hanging wire. The EFW panels can be integrated into a grid ceiling system, recessed into a plasterboard ceiling, installed as a freehanging unit or surface mounted.

Electrical Connection

All panels are fitted with a M-PE-L 3-pole push wire power connector to accommodate connecting the panel to the mains power supply.

Design

The Electric Frengerwarm Panels consists of a heating coil encased in a white painted steel panel. With an output of approximately 830 W/m², the EFW panels are one of the most efficient smooth - faced radiant heating panels currently available. As standard the panels are rated to IP55 for dust and water ingress, but as an optional extra can be supplied with silicone sealed which are rated as IP56.

Dimensions: EFW panels are available in three widths, as standard - 0.3m, 0.6m and 0.9m. These nominal dimensions are reduced by 8mm on length and width so that panels can be integrated within a traditional suspended ceiling using exposed T-bars (24mm wide) on a 600 x 600mm grid module. The depth of the panel is just 45mm.

Lengths: EFW panels are produced in nominal module lengths of 0.6m, 1.2m, 1.8m, 2.4m and 3.0m as standard; non-standard lengths are available upon request.

Surface finish: EFW panels are pre-coated White as standard equivalent to RAL 9016, gloss value 20%, emissivity 0.94, Frenger also offer all RAL classic colour options to suit any architectural aesthetics (other colours available on request).

Application

EFW panels are particularly suited for use in schools, shops and offices; in fact wherever there is a need for a high-output radiant heating panel which is simple to install, easy to keep clean and comes at a very competitive price. EFW panels are the perfect solution for integration with an exposed grid ceiling system applications but can also be recessed into a plasterboard ceiling.

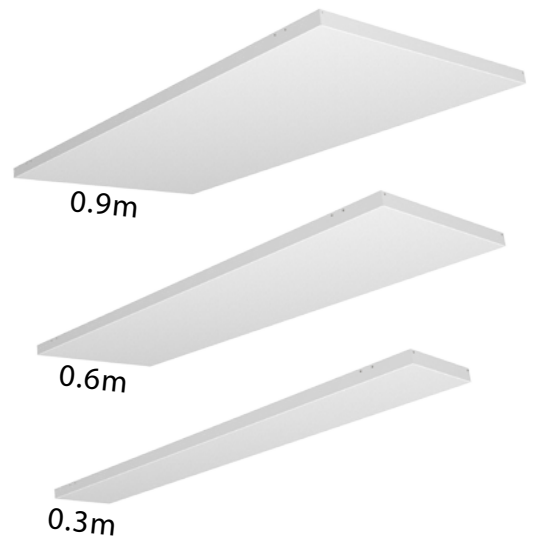

EFW Panels - Available Widths

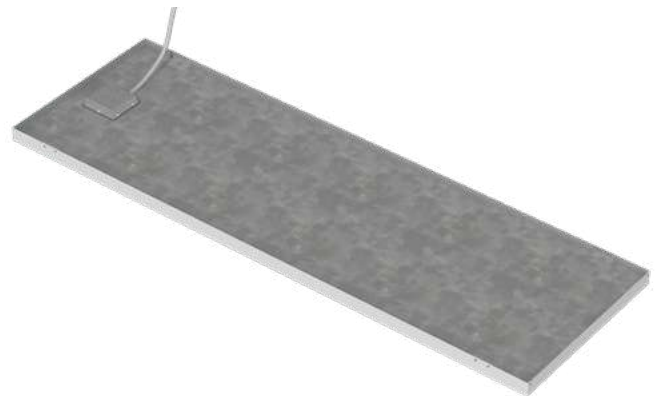

EFW Panel - Top Detail

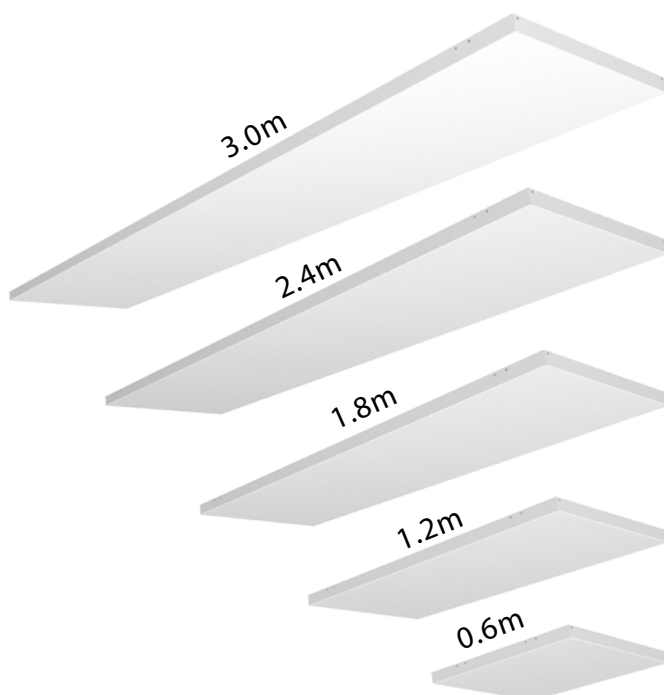

EFW Panels - Available Lengths



EFW Panel - Colour Option Examples

Installation

The EFW panels are designed to be fixed directly back to the structural soffit. Panels are supplied with support brackets which are suitable for suspension using rigid threaded rod systems or suspension cables (by others). Four hangers are required for each heating panel up to 1.8m long, panels 2.4m long and longer require 8 number hangers.

It should be remembered that the ceiling system "main runners" must be designed to run either side of the EFW panel and parallel to its long sides. Ceiling system "cross noggin" bayonets must be capable of being bent back so as not to clash with the panel. The panels can also be mounted directly onto the ceiling/soffit with ceiling mounting bracket.

0.6m, 1.2m and 1.8m long panels

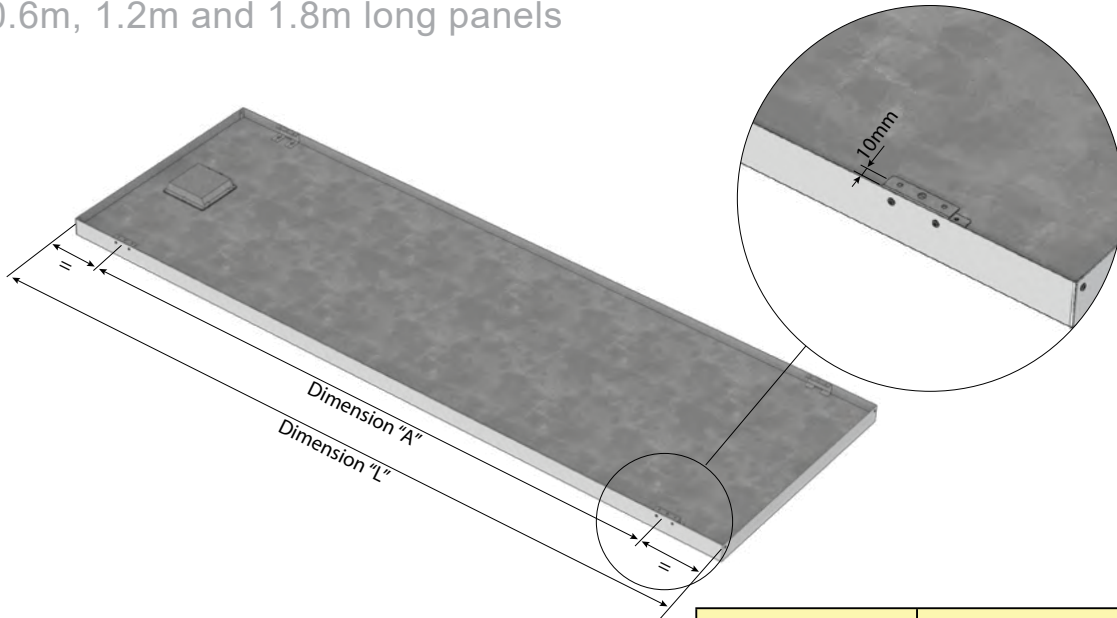

2.4m and 3.0m long panels

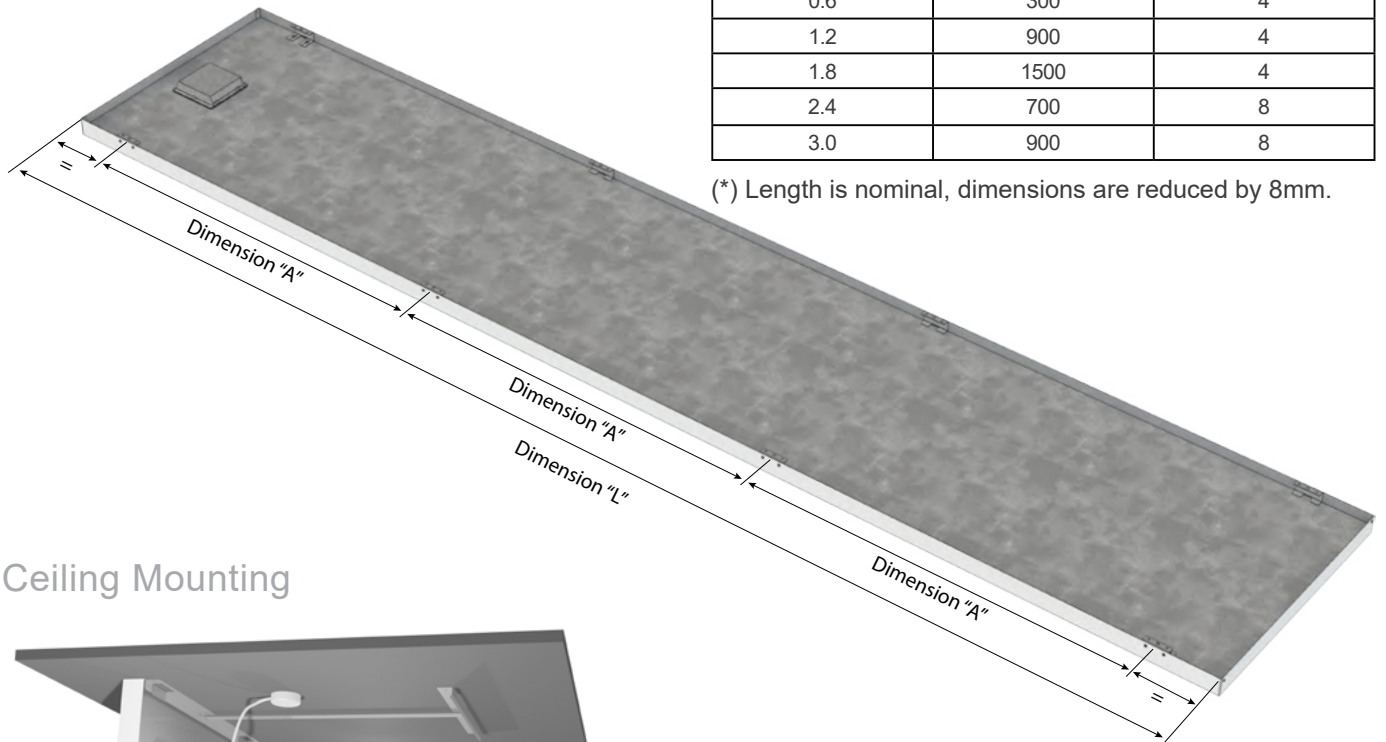

(*) Length is nominal, dimensions are reduced by 8mm.

Ceiling Mounting

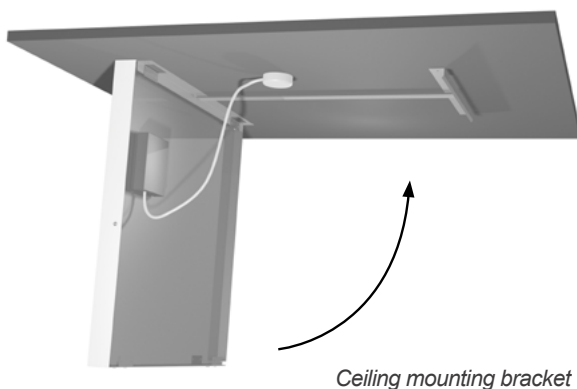

Product Dimensions

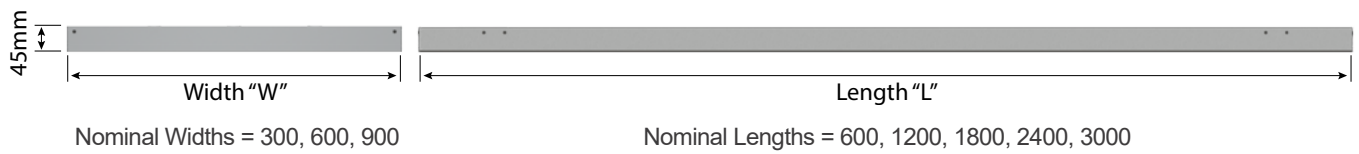

Electric Frengerwarm panels are manufactured in standard module lengths (L) from 0.6m, up to 3.0m. Actual dimensions are less 10mm to fit into standard T-bars. All panels are manufactured to a dimensional tolerance of ± 1 mm.

Installation Examples



Ceiling Integrated EFW Panels



EFW Panels Recessed into Plasterboard Ceiling

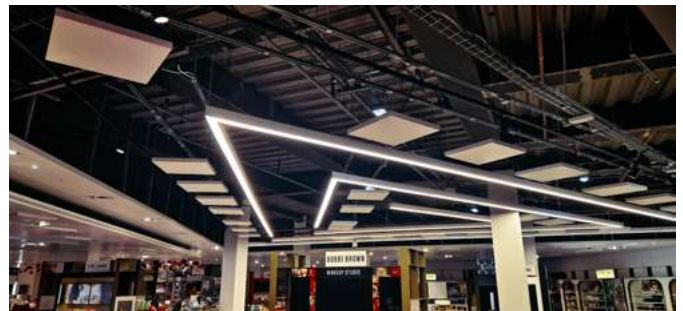

Free-Hanging EFW Panels

Installation Arrangement

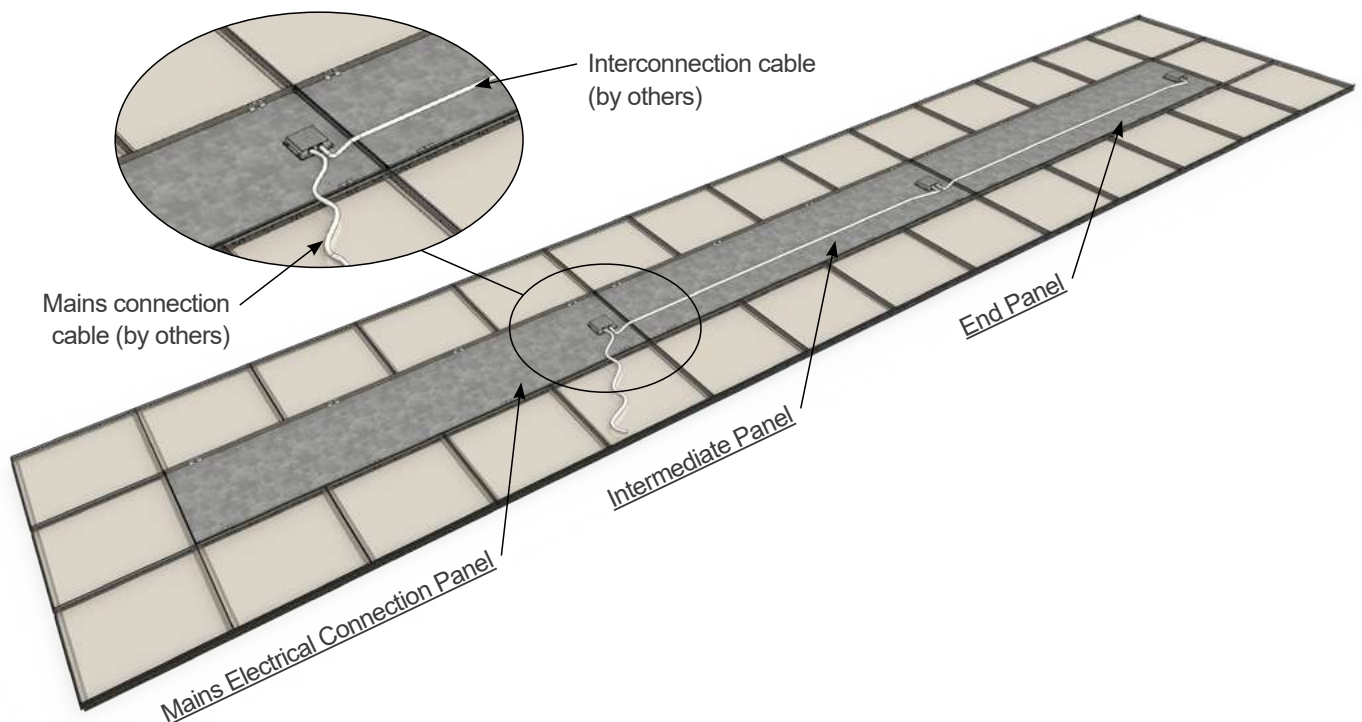

Model References

Model Reference	Width (m)	Length (m)	Depth (mm)	Voltage (V)	Heating Output (W)
EFW-3-150-IP55	0.3	0.6	45	230	150
EFW-3-300-IP55		1.2			300
EFW-3-450-IP55		1.8			450
EFW-3-600-IP55		2.4			600
EFW-3-750-IP55		3.0			750
EFW-6-300-IP55	0.6	0.6			300
EFW-6-600-IP55		1.2			600
EFW-6-900-IP55		1.8			900
EFW-6-1200-IP55		2.4			1200
EFW-6-1500-IP55		3.0			1500
EFW-9-450-IP55	0.9	0.6			450
EFW-9-900-IP55		1.2			900
EFW-9-1350-IP55		1.8			1350

Note:

- Dimensions stated above are nominal – actual dimensions are less 10mm (to suit a standard 0.6m x 0.6m lay-in ceiling grid).
- The model references above are the standard IP 55 rated version, as an optional extra they can be silicone sealed IP56.

Minimum Mounting Details

	Description	Minimum Distance
A	Heater to wall	50mm
B	Heater to flammable material	200mm
C	Heater to floor	1800mm



Controls

Frenger can supply our easy to install T60-EH controller with built in thermostat, which has a full colour touch screen and three programming modes (Weekday / Weekend, Seven Day and 24 Hour Mode). The controller is suitable for flush mounting and requires a minimum 35mm deep junction box, recessed into the wall.

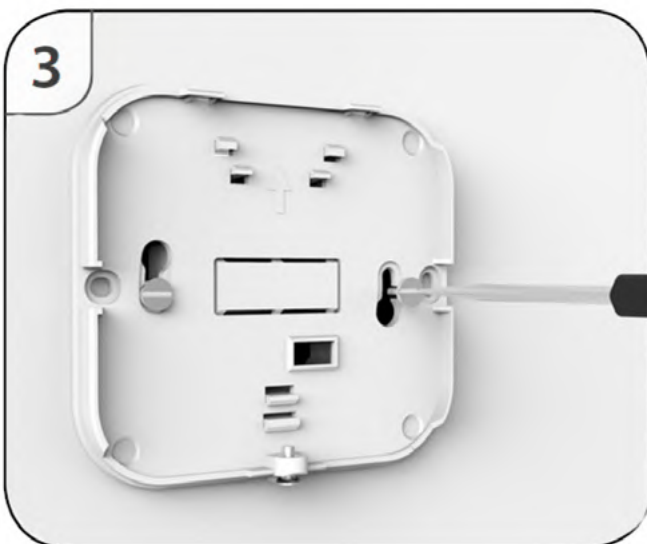
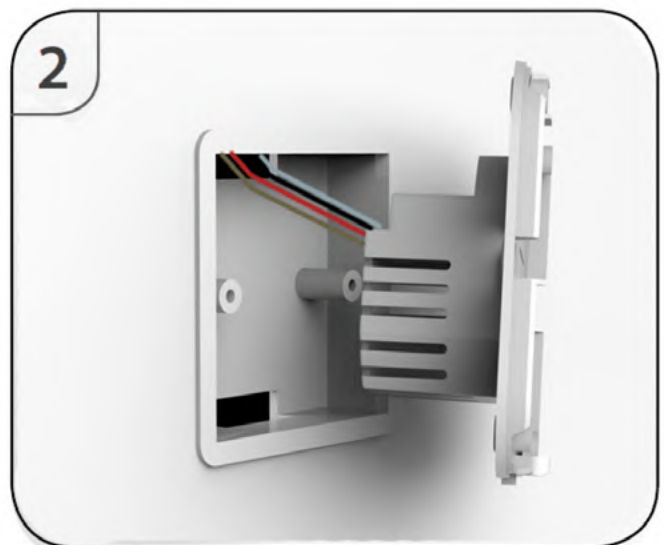

Product Testing

Frenger are a BSI (British Standards Institute) accredited company operating a QMS (Quality Management System) to BS EN ISO 9001:2015.

Frenger are committed to ensuring the highest quality, performance and safety for all their products. The EFW panels undergo rigorous independent testing and certification to various standards. This is to make sure that the EFW panels meet and exceed industry expectations for Electrical Safety, Ingress Protection, Electromagnetic Compatibility (EMC), and the Evaluation of Electromagnetic Fields (EMF). The commitment to quality assurance for the EFW panels ensures a reliable, efficient product which is at the forefront of industry standards.

Electrical Safety

The EFW Panels were certified for Electrical Safety by Eurofins who carried out testing in accordance with the following specifications:

- EN 60335-2-30:2009 + A1/11
- EN 60335-1:2012 + A11/13/1/14/2/15

Ingress Protection (IP55 & IP56)

The EFW Panels were certified for Ingress Protection by Mariner Systems Limited who carried out testing in accordance with the following specifications:

- EN 60529: 1992 + A2:2013 (IP55 & IP56)

The testing carried out included:

- IP5X - Dust Ingress
- IPX5 - Water Ingress
- IPX6 - Water Ingress (Optional Silicone Sealed Model)



EFW Panel Electrical Safety Testing Certificate



EFW Panel During Dust Ingress Testing



EFW Panel Ingress Protection Certificate (IP55)



EFW Panel During Water Ingress Testing

Product Testing

Electromagnetic Compatibility

The EFW Panels were certified for Electromagnetic Compatibility (EMC) by Mariner Systems Limited who carried out testing in accordance with the following specifications:

- EN 55014-1: 2021
- EN 55014-2: 2015
- EN 61000-3-2: 2019
- EN 61000-3-3: 2013 +A2: 2021

The testing carried out included:

Electrostatic Discharge Immunity Test, Radiated, radio frequency, electromagnetic field immunity test, Electrical fast transient/burst immunity test, Surge immunity test, Immunity to conducted disturbances, induced by radio frequency fields, Voltage dips, short interruptions and voltage variations immunity test, Radiated disturbance measurements, Conducted disturbance measurements, Discontinuous Interference, Harmonics and Flicker.

Evaluation of Electromagnetic Fields

The EFW Panels were evaluated and certified for Electromagnetic Field (EMF) strength in regards to human exposure by Eurofins who carried out testing in accordance with the following specifications:

- EN 62233: 2008 - Evaluation of the magnetic fields.

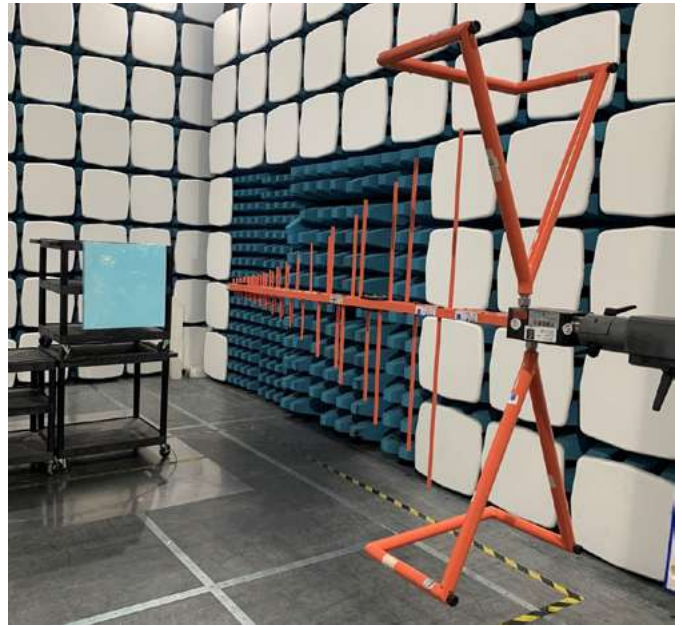

EFW Panel Electromagnetic Compatibility Testing - With a Chase CBL 6143A Antenna

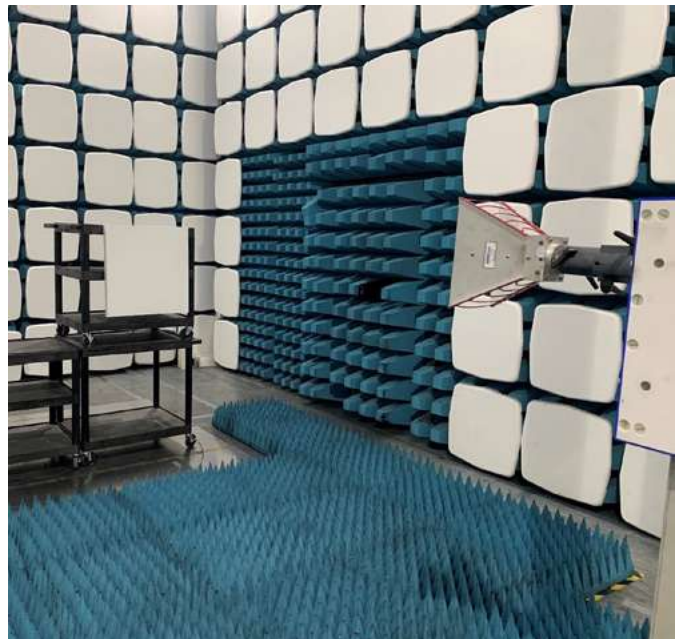

EFW Panel Electromagnetic Compatibility Testing - With a ETS-Lindgren's Model 3115 Double-Ridged Guide Horn Antenna

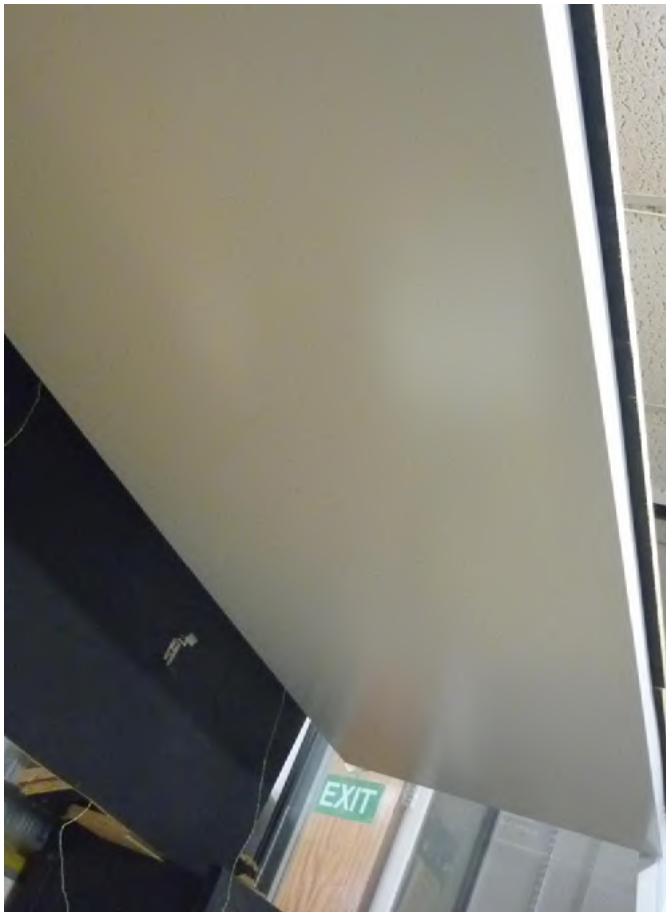

EFW Panel During Evaluation of Magnetic Field

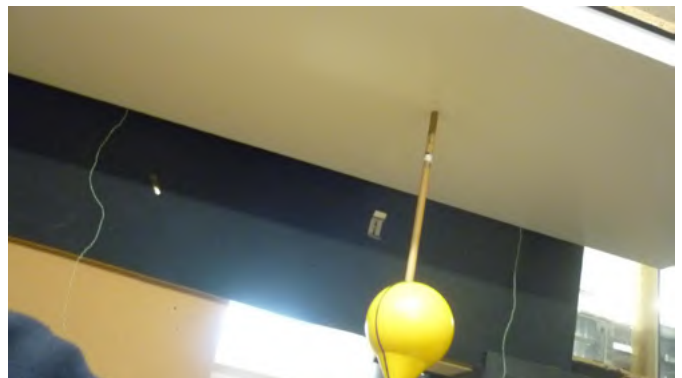

EFW Panel During Evaluation of Magnetic Field

Bespoke Manufacturing

Frenger has the manufacturing capability required to deliver the most complex of bespoke solutions. Facilities include the latest full CNC machine centers, together with a dedicated powder-coat paint plant to paint all of the components of the products and project specific in-house testing laboratories.



Project Specific Testing Facility

The 3 number state-of-the-art Climatic Testing Laboratories at Frenger's technical facility in Derby (UK) have internal dimensions of 6.3m (L) x 5.7m (W) x 3.3m (H) high and includes a thermal wall so that both internal and perimeter zones can be simulated. Project specific testing validates product / solution performance (outputs) and resultant Room Comfort Conditions for compliance category grading in accordance with BS EN ISO 7730. All of Frenger's chilled beams have also been independently tested and certified by Eurovent in terms of product performance (output), as Eurovent can not test for thermal comfort; hence the need for Frenger's own laboratories.

Project Specific Testing

Project specific mock-up testing is a valuable tool which allows the Client to fully assess the proposed system and determine the resulting room occupancy Thermal Comfort conditions. The physical modelling is achieved by installing a full scale representation of a building zone complete with internal & external heat gains (Lighting, Small Power, Occupancy & Solar Gains).

The installed mock-up enables the client to verify the following:

- Product performance under project specific conditions.
- Spatial air temperature distribution.
- Spatial air velocities.
- Experience thermal comfort.
- Project specific aesthetics.
- Experience lighting levels (where relevant).
- Investigate the specific design and allow the system to be optimised.



The project-specific installation and test is normally conducted to verify:

- Product capacity under design conditions.
- Comfort levels - air temperature distribution.
 - thermal stratification.
 - draft risk.
 - radiant temperature analysis.
- Smoke test video illustrating air movement.
- Live Thermal Imaging

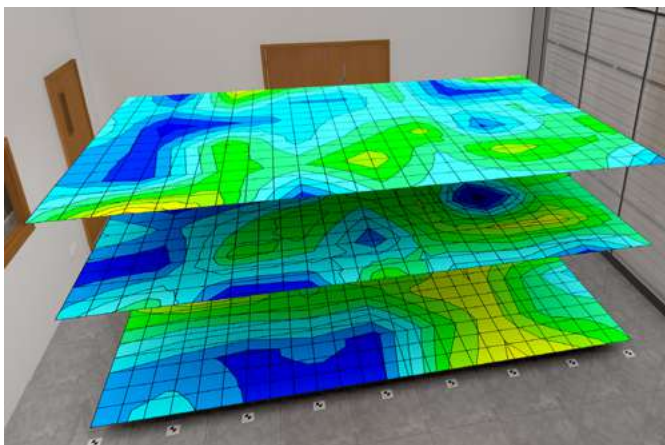

Photometric Testing Facility

The in-house Photometric test laboratories at Frenger are used to evaluate the performance of luminaires. To measure the performance, it is necessary to obtain values of light intensity distribution from the luminaire. These light intensity distributions are used to mathematically model the lighting distribution envelope of a particular luminaire. This distribution along with the luminaires efficacy allows for the generation of a digital distribution that is the basis of the usual industry standard electronic file format. In order to assess the efficacy of the luminaire it is a requirement to compare the performance of the luminaire against either a calibrated light source for absolute output or against the “bare” light source for a relative performance ratio.

The industry uses both methods. Generally absolute lumen outputs are used for solid state lighting sources and relative lighting output ratios (LOR) are used for the more traditional sources. Where the LOR method is chosen then published Lamp manufacturer’s data is used to calculate actual lighting levels in a scheme and for LED light source the integration chamber is used to measure LED luminance efficacy.

The intensity distribution is obtained by the use of a Goniophotometer to measure the intensity of light emitted from the surface of the fitting at pre-determined angles. The light intensity is measured using either a photometer with a corrective spectral response filter to match the CIE standard observer curves or our spectrometer for LED sources.

Luminaire outputs are measured using our integrating sphere for smaller luminaires or our large integrator room for large fittings and Multi Service Chilled Beams. For both methods we can use traceable calibrated radiant flux standards for absolute comparisons.

All tests use appropriate equipment to measure and control the characteristics of the luminaire and include air temperature measurements, luminaire supply voltage, luminaire current and power. Thermal characteristics of luminaire components can be recorded during the testing process as required.

A full test report is compiled and supplied in “locked” PDF format. Data is collected and correlated using applicable software and is presented electronically to suit, usually in Eulumdat, CIBSE TM14 or IESN standard file format.

Frenger conduct photometric tests in accordance with CIE 127:2007 and BS EN 13032-1 and sound engineering practice as applicable. During the course of these tests suitable temperature measurements of parts of LED’s can be recorded. These recorded and plotted temperature distributions can be used to provide feedback and help optimise the light output of solid state light source based luminaires which are often found to be sensitive to junction temperatures.

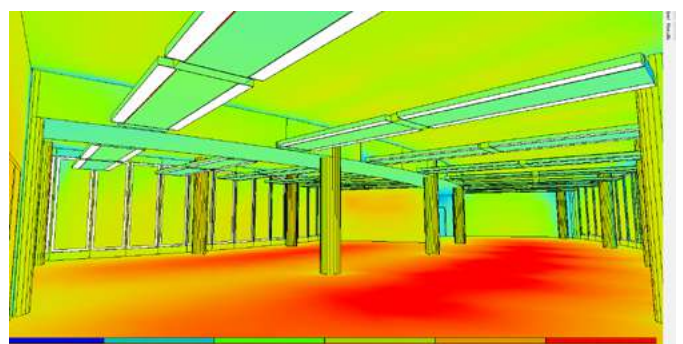

Acoustic Testing Facility

The Acoustic Test Room at Frenger is a hemi-anechoic chamber which utilises sound absorbing acoustic foam material in the shape of wedges to provide an echo free zone for acoustic measurements; the height of the acoustic foam wedge has a direct relationship with the maximum absorption frequency, hence Frenger had the acoustic wedges specifically designed to optimise the sound absorption at the peak frequency normally found with our active chilled beam products.

The use of acoustic absorbing material within the test room provides the simulation of a quiet open space without “reflections” which helps to ensure sound measurements from the sound source are accurate, in addition the acoustic material also helps reduce external noise entering the test room meaning that relatively low levels of sound can be accurately measured.

The acoustic facilities allow Frenger to provide express in-house sound evaluation so that all products, even project specific designs can be quickly and easily assessed and optimised.

To ensure accuracy, Frenger only use Class 1 measurement equipment which allows sound level measurements to be taken at 11 different $\frac{1}{3}$ octave bands between 16 Hz to 16 kHz, with A, C and Z (un-weighted) simultaneous weightings.

In addition to the above, Frenger also send their new products to specialist third party Acoustic Testing. The results of which are very close and within measurement tolerances to that of Frenger’s in-house measurement of sound.

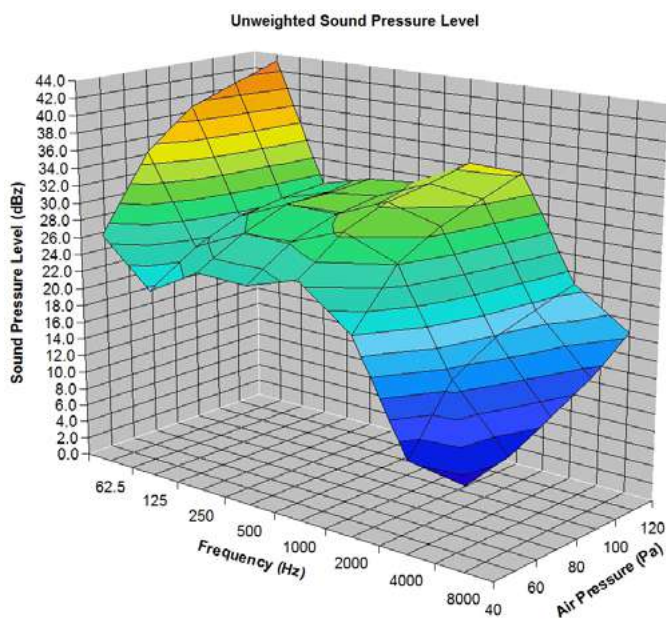
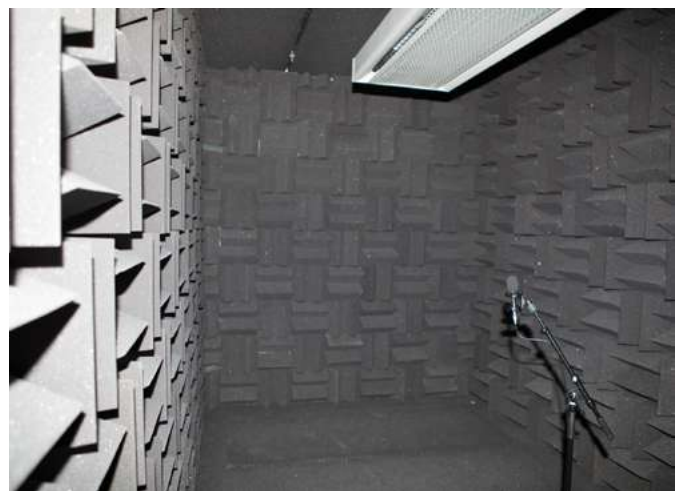
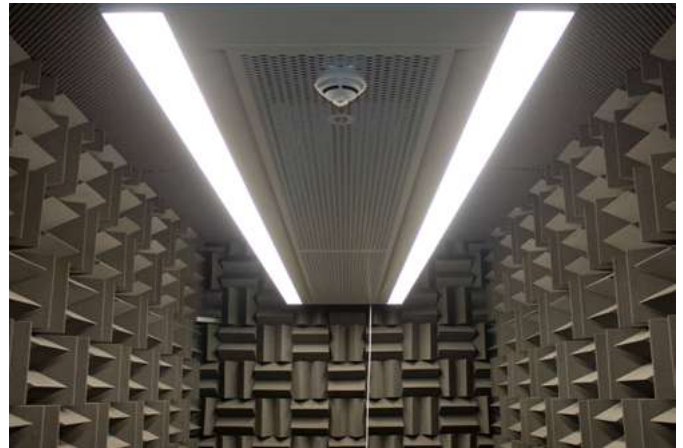

Industry Associations

Always mindful of its place within the HEVAC industry, Frenger Systems pride themselves on broad range of trade associations and accreditations. With a clear service, product and environmental ethos across everything they do, Frenger is focused on meeting and consistently surpassing the expectations of its customers. Frenger invest heavily in achieving industry recognised accreditations and as part of ongoing commitment to their customers and continually assess the level of services they provide. Opening up their company to these independent organisations allows Frenger to continually improve their customer service and satisfaction.

As an engaged member of the HEVAC industry, Frenger are actively asked to participate in industry specific discussions and studies. With this in mind Frenger are proud to have achieved and be linked with the following associations:



BSI EN ISO 9001:2015

Frenger Systems are registered by BSI for operating a Quality Management System which complies with the requirements of BS EN 9001:2015.



Eurovent

Frenger Systems participate in the EC programme for Chilled Beams. Check ongoing validity of certificate: www.eurovent-certification.com or www.certiflash.com 



Chilled Beam and Ceiling Association

The Chilled Beam and Ceiling Association has been formed by leading companies within the construction industry. The objective of the Association is to promote the use of Chilled Beams and Chilled Ceilings, and encourage best practice in their development and application.



HEVAC Member

HEVAC is the heating and ventilating contractors association. As a HEVAC member Frenger Systems are subject to regular, third party inspection and assessment to ensure their technical and commercial competence.



Federation of Environment Trade Association

The Federation of Environment Trade Association (FETA), of which Frenger Systems is a member of, is the recognised UK body which represents the interests of manufacturers, suppliers, installers and contractors within the heat pump, controls, ventilating, refrigeration & air conditioning industry.



UK Trade & Investment

Frenger Systems are members of both the UK TI (the former Department of Trade and Industry) as well as the Chamber of Commerce for Export Documentation.



Certified CIBSE CPD

Frenger Systems is a CIBSE approved "Continued Professional Development" (CPD) provider. Frenger offers 1 hour lunch time CPD presentations regarding "Chilled Beam Technology", CPD presentations are usually held at Consulting Engineers local practices with lunch provided courtesy of Frenger. Alternatively half or full day Chilled Beam Technology training is available at Frenger's UK Technical Academy in a dedicated training theatre with fully operational BMS system with various different Chilled Beam and Ceiling solutions integrated.

Booking of a CPD Presentation can be requested on Frenger's home page, under the drop down menu headed "Company", then "CPD Booking". Alternatively email sales@frenger.co.uk.



UK Head Office

Frenger Systems Ltd
Riverside Road
Pride Park
Derby
DE24 8HY

tel: +44 0 1332 295 678
fax: +44 0 1332 381 054
sales@frenger.co.uk
www.frenger.co.uk

Australian Office

Frenger
Level 20
Tower 2
201 Sussex Street
Sydney
NSW 2000
Australia

tel: +61 2 9006 1147
fax: +61 2 9006 1010
sales@frenger.com.au
www.frenger.com.au

American Office

FTF Group Climate
1501 Broadway, Times Square
12th Floor
New York
NY 10036
United States of America

tel: +00 1 646 571 2151
fax: +00 1 646 571 2001
sales@ftfgroup.us
www.ftfgroup.us

Independently Tested Output to BS EN 14037



Frenger is an **FTF Group** Company
Registered No. 646 6229 20

www.frenger.co.uk