

the future of space conditioning

Frenger Electric

radiant heating





Contents

EFW - Electric Frengerwarm	3
- Introduction	3
- Technical Data	4
- Mounting & Installation	5
- Product Testing	6
Frenger ES	9
- Introduction	9
- Technical Data	10
- Mounting & Installation	11
Frenger IR	14
- Introduction	14
- Technical Data	15
- Mounting & Installation	16
Frenger IRI	18
- Introduction	18
- Technical Data	19
- Mounting & Installation	20
Accessories	22
- T60-EH Controller	22
Bespoke Manufacturing	23
Project Specific Testing Facility	24
Photometric Testing Facility	25
Acoustic Testing Facility	26
Industry Associations	27

EFW - Electric Frengerwarm



EFW Radiant Heating Panel

Introduction

Electric Frengerwarm (EFW) is an unobtrusive radiant heating panel. The panels are manufactured from 1.0mm thick steel with a pre painted tough Pre-coat finish, equivalent to RAL 9016 (White) as standard, other Powder coat RAL colours available on request. These panels are primarily designed to be integrated within a standard 24mm exposed grid ceiling system, although can be surface mounted (optional brackets available) or free-hanging (exposed) application.

The electric version of the Frengerwarm radiant heating panel supplies gentle, even, and comfortable heat in various applications. The heaters can be used to provide general heating, or to raise temperature in certain areas (spot heating). The panel face temperature is between 90°C and 100°C and provides 830 W/m² of heat output.

As the EFW electric panel uses radiant heat, which is concentrated in the occupied area thus minimising energy losses through stratification of heated air.

The EFW electric panels have been specifically developed for use in schools and healthcare environments where a smooth faced simple-to-install panel with high heating capacity is the preferred solution.



Standard Features

- Modular system to fit into 600mm exposed grid ceiling.
- Modular lengths; 0.6m, 1.2m, 1.8m, 2.4m, 3.0m.
- Modular widths; 0.3m, 0.6m, 0.9m.
- Panel depth 45mm.
- Smooth faced, unobtrusive design.
- Pre coat finished White, equivalent to RAL 9016 20% gloss ($\pm 5\%$).
- 830 W/m² heat output.
- 90°C to 100°C surface temperature.
- Weight: less than 15.5 kg / m².

Maintenance

The unit has no moving parts, and therefore maintenance requirement is limited to periodic cleaning of the surface of the panel using warm water applied with a soft cloth then wiped dry.

Installation

Standard fixing arrangement from the structural soffit using rigid threaded rod (supplied by others) or suitable hanging wire. The EFW panels can be integrated into a grid ceiling system, recessed into a plasterboard ceiling, installed as a free-hanging unit (fully exposed) or surface mounted.

Electrical Connection

All panels are fitted with a M-PE-L 3-pole push wire power connector to accommodate connecting the panel to the mains power supply and/or linking one panel to the next panel in series (maximum 3600W for the entire linked run of panels).

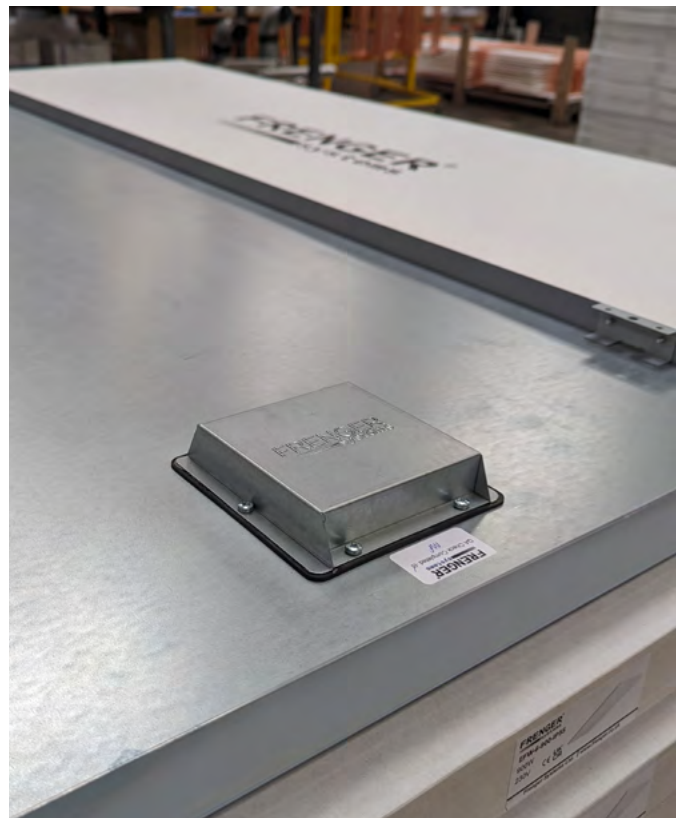

Technical Data

Model Reference	Width (m)	Length (m)	Depth (mm)	Voltage (V)	Heating Output (W)
EFW-3-150-IP55	0.3	0.6	45	230	150
EFW-3-300-IP55		1.2			300
EFW-3-450-IP55		1.8			450
EFW-3-600-IP55		2.4			600
EFW-3-750-IP55		3.0			750
EFW-6-300-IP55	0.6	0.6			300
EFW-6-600-IP55		1.2			600
EFW-6-900-IP55		1.8			900
EFW-6-1200-IP55		2.4			1200
EFW-6-1500-IP55		3.0			1500
EFW-9-450-IP55	0.9	0.6			450
EFW-9-900-IP55		1.2			900
EFW-9-1350-IP55		1.8			1350

Note:

- Dimensions stated above are nominal – actual dimensions are less 10mm (to suit a standard 0.6m x 0.6m lay-in ceiling grid).
- The model references above are the standard IP 55 rated version, as an optional extra they can be silicone sealed IP56.

Control

Frenger can supply our easy to install T60-EH controller with built in thermostat, which has a full colour touch screen and three programming modes (Weekday / Weekend, Seven Day and 24 Hour Mode). The controller is suitable for flush mounting and requires a minimum 35mm deep junction box, recessed into the wall.

Design

The Electric Frengerwarm Panels consists of a heating coil encased in a white painted steel panel. With an output of approximately 830 W/m², the EFW panels are one of the most efficient smooth - faced radiant heating panels currently available. As standard the panels are rated to IP55 for dust and water ingress, but as an optional extra can be supplied with silicone sealed which are rated as IP56.

Product Testing & Independent Certification

Frenger are a BSI (British Standards Institute) accredited company operating a QMS (Quality Management System) to BS EN ISO 9001:2015.

Frenger are committed to ensuring the highest quality, performance and safety for all their products. The EFW panels undergo rigorous independent testing and certification to various standards. This is to make sure that the EFW panels meet and exceed industry expectations for Electrical Safety, Ingress Protection, Electromagnetic Compatibility (EMC), and the Evaluation of Electromagnetic Fields (EMF). The

commitment to quality assurance for the EFW panels ensures a reliable, efficient product which is at the forefront of industry standards. All EFW panels are certified to the following standards:

Electrical Safety

- EN 60335-2-30:2009 + A1/11
- EN 60335-1:2012 + A11/13/1/14/2/15

Ingress Protection (IP55 & IP56)

- EN 60529: 1992 + A2:2013

Electromagnetic Compatibility

- EN 55014-1: 2021
- EN 55014-2: 2015
- EN 61000-3-2: 2019
- EN 61000-3-3: 2013 +A2: 2021

Evaluation of Magnetic Fields

- EN 62233: 2008



EFW Panel Electrical Safety Testing Certificate

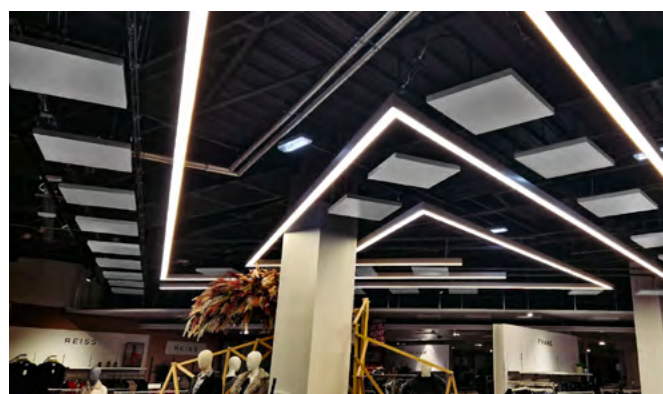

Mounting & Installation

The EFW panels are designed to be fixed directly back to the structural soffit. Panels are supplied with factory fitted support brackets which are suitable for suspension using rigid threaded rod systems or suspension cables (by others). Four hangers are required for each heating panel up to 1.8m long, panels 2.4m long and longer require 8 number hangers.

0.6m, 1.2m and 1.8m long panels

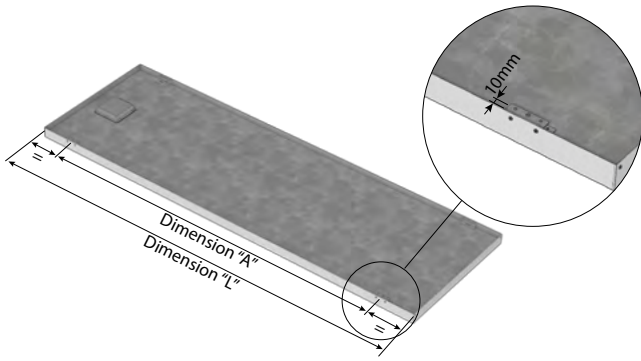

Ceiling Mounting

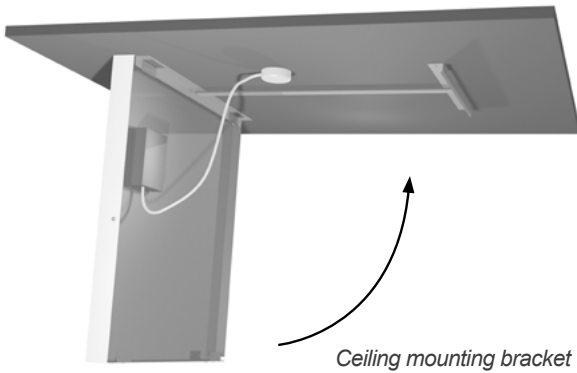

Minimum Mounting Distances



It should be remembered that the ceiling system "main runners" must be designed to run either side of the EFW panel and parallel to its long sides. Ceiling system "cross noggin" bayonets must be capable of being bent back so as not to clash with the panel. The panels can also be mounted directly onto the ceiling/soffit with ceiling mounting bracket.

2.4m and 3.0m long panels

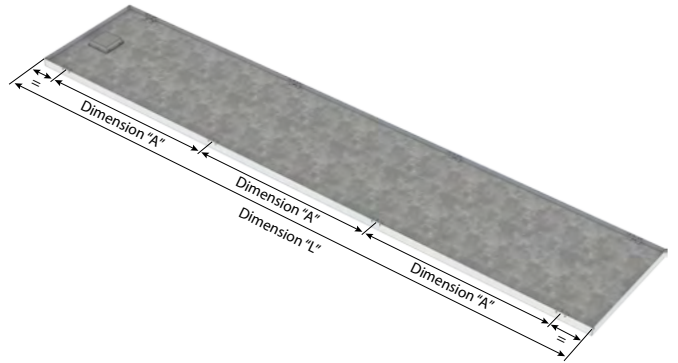

Dimension "L" (*)	Dimension "A" (mm)	Number of Support Brackets
0.6	300	4
1.2	900	4
1.8	1500	4
2.4	700	8
3.0	900	8

(*) Length is nominal, dimensions are reduced by 8mm.

	Description	Minimum Distance
A	Heater to wall	50mm
B	Heater to flammable material	200mm
C	Heater to floor	1800mm

Product Testing

Frenger are a BSI (British Standards Institute) accredited company operating a QMS (Quality Management System) to BS EN ISO 9001:2015.

Frenger are committed to ensuring the highest quality, performance and safety for all their products. The EFW panels undergo rigorous independent testing and certification to various standards. This is to make sure that the EFW panels meet and exceed industry expectations for Electrical Safety, Ingress Protection, Electromagnetic Compatibility (EMC), and the Evaluation of Electromagnetic Fields (EMF). The commitment to quality assurance for the EFW panels ensures a reliable, efficient product which is at the forefront of industry standards.

Electrical Safety

The EFW Panels were certified for Electrical Safety by Eurofins who carried out testing in accordance with the following specifications:

- EN 60335-2-30:2009 + A1/11
- EN 60335-1:2012 + A11/13/1/14/2/15

Ingress Protection (IP55 & IP56)

The EFW Panels were certified for Ingress Protection by Mariner Systems Limited who carried out testing in accordance with the following specifications:

- EN 60529: 1992 + A2:2013 (IP55 & IP56)

The testing carried out included:

- IP5X - Dust Ingress
- IPX5 - Water Ingress
- IPX6 - Water Ingress (Optional Silicone Sealed Model)



EFW Panel Ingress Protection Certificate (IP55)



EFW Panel Electrical Safety Testing Certificate



EFW Panel During Dust Ingress Testing

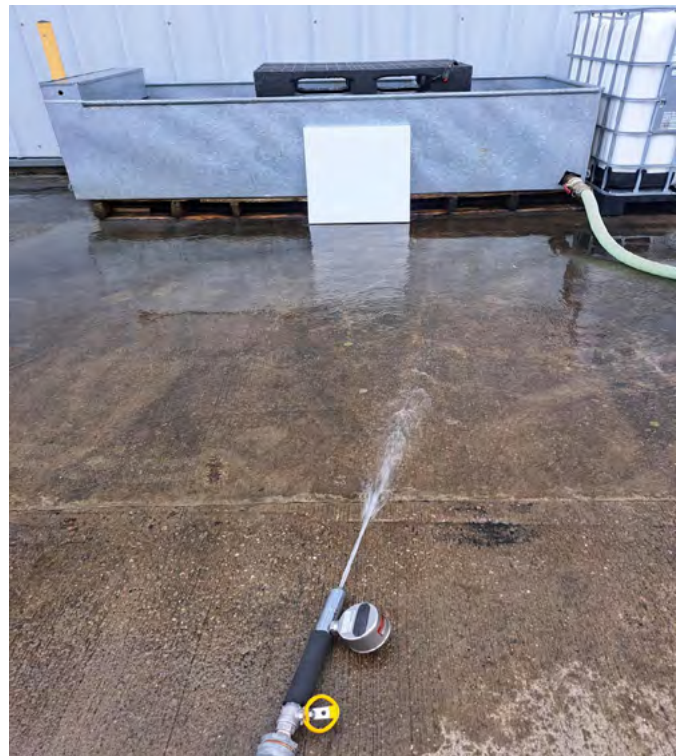

EFW Panel During Water Ingress Testing

Product Testing

Electromagnetic Compatibility

The EFW Panels were certified for Electromagnetic Compatibility (EMC) by Mariner Systems Limited who carried out testing in accordance with the following specifications:

- EN 55014-1: 2021
- EN 55014-2: 2015
- EN 61000-3-2: 2019
- EN 61000-3-3: 2013 +A2: 2021

The testing carried out included:

Electrostatic Discharge Immunity Test, Radiated, radio frequency, electromagnetic field immunity test, Electrical fast transient/burst immunity test, Surge immunity test, Immunity to conducted disturbances, induced by radio frequency fields, Voltage dips, short interruptions and voltage variations immunity test, Radiated disturbance measurements, Conducted disturbance measurements, Discontinuous Interference, Harmonics and Flicker.

Evaluation of Electromagnetic Fields

The EFW Panels were evaluated and certified for Electromagnetic Field (EMF) strength in regards to human exposure by Eurofins who carried out testing in accordance with the following specifications:

- EN 62233: 2008 - Evaluation of the magnetic fields.



EFW Panel Electromagnetic Compatibility Testing - With a Chase CBL 6143A Antenna

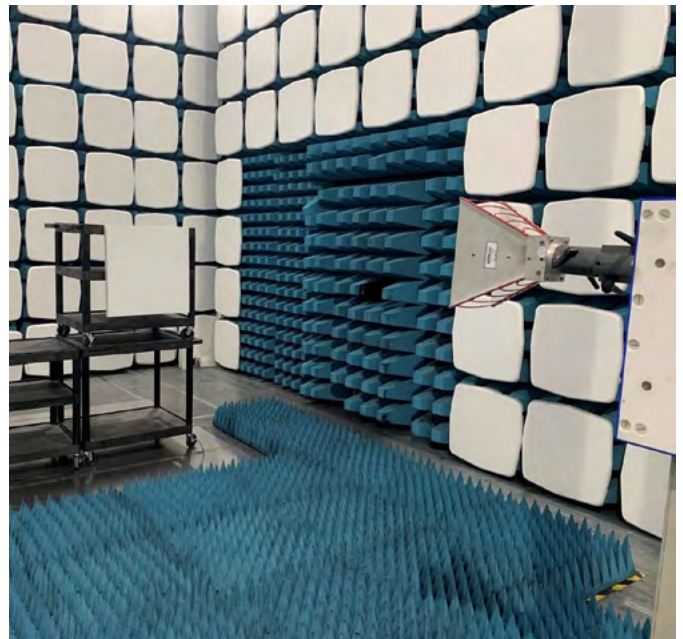

EFW Panel Electromagnetic Compatibility Testing - With a ETS-Lindgren's Model 3115 Double-Ridged Guide Horn Antenna

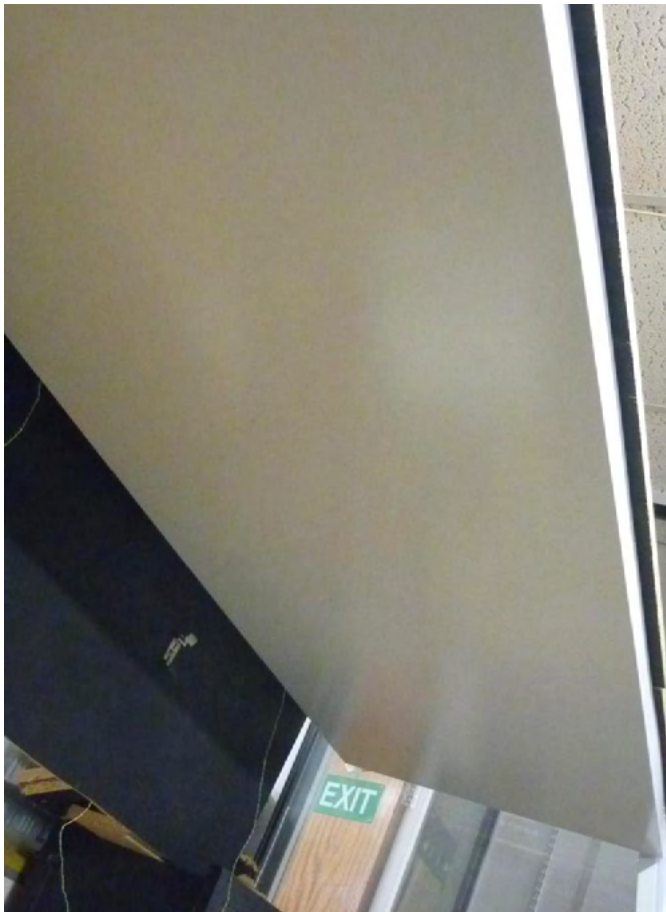

EFW Panel During Evaluation of Magnetic Field

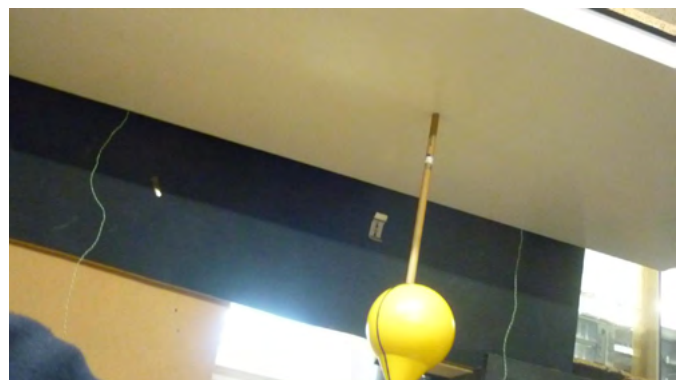

EFW Panel During Evaluation of Magnetic Field



Frenger ES



ES Radiant Heater

Introduction

Frenger's ES will supply gentle, even and comfortable heat in various applications from small stores or bathrooms to large industrial units. The heaters can be used to provide general heating, or to raise the temperature in certain areas (spot heating).

The heat is concentrated in the occupied area, thus minimising energy losses through the stratification of heated air. The system is simple and inexpensive to install and maintenance free.

Frenger's ES heater emits a gentle, pleasant radiant heat (infrablack, long wave), not to be confused with high temperature shortwave infrared heat. The product is consequently ideal to use for general heating of small or large areas where installation heights are between 2 - 40m from floor height.

Benefits of Radiant Heating

- Possible to maintain 3 - 6°C lower air temperature than with conventional heating.
- Concentrates heat to the occupied zone.
- Minimising warm - up times.

Benefits of Frenger ES Radiant Heaters

- No moving parts equates to reduced maintenance costs.
- Ceiling mounted unit frees up wall and floor space.
- Suitable for mounting between 2 - 40m from floor level.
- Large selection of outputs available.
- Splash proof IP44.

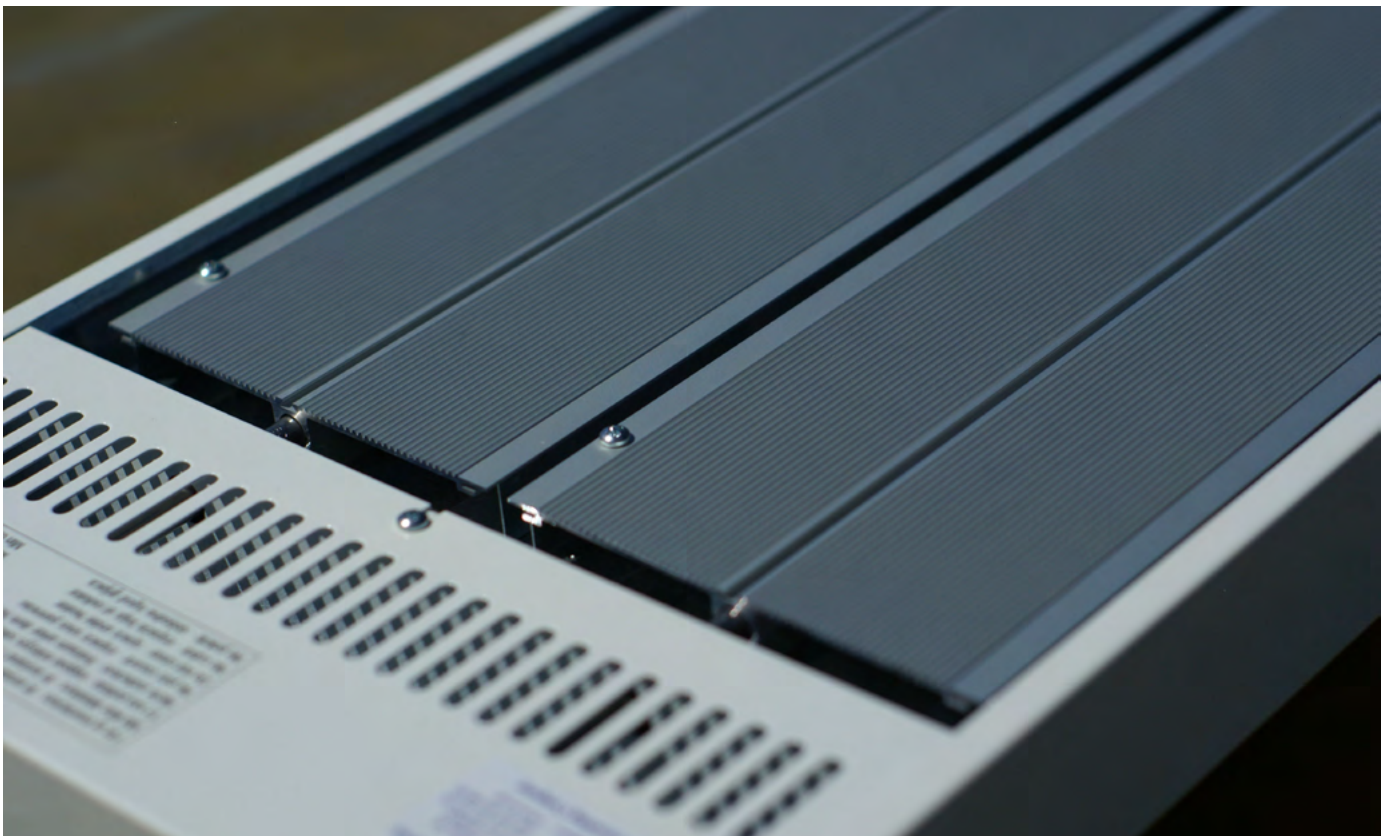

Technical Data

Part No.	Heating Capacity (W)	Voltage (V)	Heating Element	Size (LxWxD) mm	Weight (Kg)	Finish
ES6	600	230	1	960 x 160 x 50	5.0	Powder coat
ES10	1000	230	1	1680 x 160 x 50	8.5	Powder coat
ES8	800	230	2	650 x 290 x 50	6.0	Powder coat
ES12	1200	230	2	960 x 290 x 50	8.5	Powder coat
ES16	1600	230	2	1360 x 290 x 50	11.5	Powder coat
ES20	2000	230	2	1680 x 290 x 50	14.0	Powder coat
ES36	3600	400	3	1680 x 430 x 50	20.0	Zinc

Control

Frenger can supply a range of suitable thermostats to be used with Frenger ES radiant heaters at an additional cost. Should you require any assistance in selection please contact our technical sales department.

Design

Frenger ES range of radiant heaters are discreet aesthetically pleasing heaters that offers easy installation with the included mounting brackets. The casing is made of white powder coated sheet steel except the ES36, where the casing is manufactured from naturally galvanised sheet steel. Alternate RAL colour finishes are available for ES6 - ES20 upon request.



Mounting & Installation

Frenger ES radiant strip heaters offers easy installation with the included mounting brackets. Alternatively panels can be installed with drop rods or chain (supplied by others), however we would recommend the ES36 units are installed with the fixing brackets provided.

Part No.	ES6	ES10	ES8	ES12	ES16	ES20	ES36
Dimension 'E' (mm)	600	1030	370	600	820	1030	1030

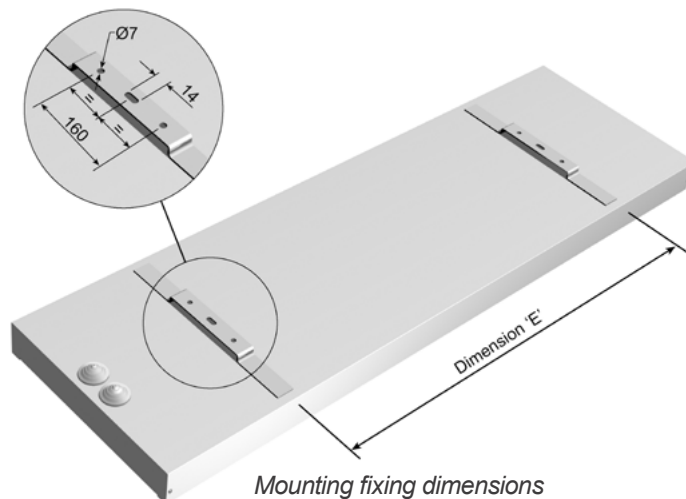

Minimum Mounting Distances

	Description	Minimum Distance
A	Heater to wall	ES6-ES20 - 150mm, ES36 - 250mm
B	Heater to flammable material	ES6-ES20 - 300mm, ES36 - 800mm
C	Heater to floor	2300mm *
D	Heater to ceiling	ES6-ES20 - 70mm, ES36 - 120mm

* Dependant on model. Contact Frenger's technical department for further information.



Minimum mounting distances





57713

SE-HTB

Frenger IR

Introduction

Frenger IR range of high radiant intensity heaters are versatile and effective. The output and format of the heater makes it ideal for installations in conservatories, balconies, patios and outdoor restaurants as well as being a good alternative for general heating of industrial buildings with high heat losses or air infiltration losses. Frenger IR heaters are often used to provide spot heating to loading bays, manufacturing facilities and various agricultural buildings.

The heaters are approved to IP44 and can as such be used in wet and dry areas alike.



Frenger IR Radiant Heater

Benefits of Radiant Heating

- Possible to maintain 3 - 6°C lower air temperature than with conventional heating.
- Concentrated heat to the occupied zone.
- Minimising warm - up times.

Benefits of Frenger IR Heaters

- No moving parts equates to reduced maintenance costs.
- Suitable for mounting between 2 - 5m from floor level.
- Suitable for wall or ceiling mounting with included brackets.
- Suitable for outdoor applications.
- Splash proof IP44.



Technical Data

Part No.	Heating Capacity (W)	Voltage (V)	Size (LxWxD) mm	Weight (Kg)
IR500	500	230	700 x 75 x 40	1.5
IR1000	1000	230	1170 x 75 x 40	2.0
IR1500	1500	230	1680 x 75 x 40	3.0

Control

Frenger can supply a range of suitable thermostats to be used with the Frenger IR heater range at an additional cost. Should you require any assistance in selection please contact our technical sales department.

Design

The Frenger IRI heaters consist of a heating element and shiny anodised aluminium reflectors encased in a stainless steel casing to ensure optimum corrosion resistance yet still being aesthetically pleasing.

Frenger IRI heaters have a solid stainless steel round bar as the heat emitter element, not glass tubes that emit unwanted light, as associated with competitors Quartz and Halogen tube emitters.



Mounting & Installation

Frenger IR offers easy installation using the included adjustable mounting brackets. The brackets can be adjusted to angle the heater in different positions enabling direction of the heat to the desired areas.

The heaters can also be suspended from chains, wires etc... (suspension equipment by others).

Part No.	IR500	IR1000	IR1500
Dimension 'E' (mm)	500	810	1100

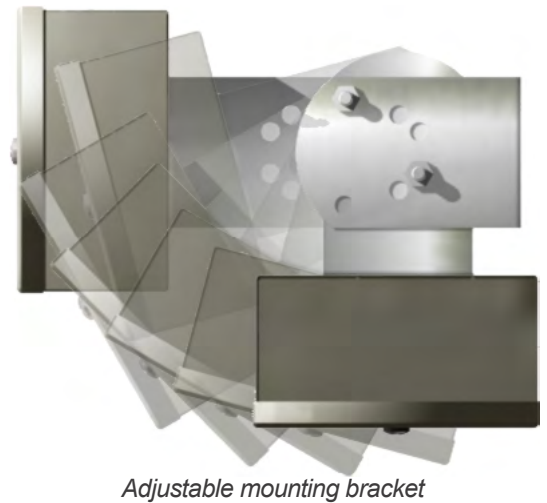
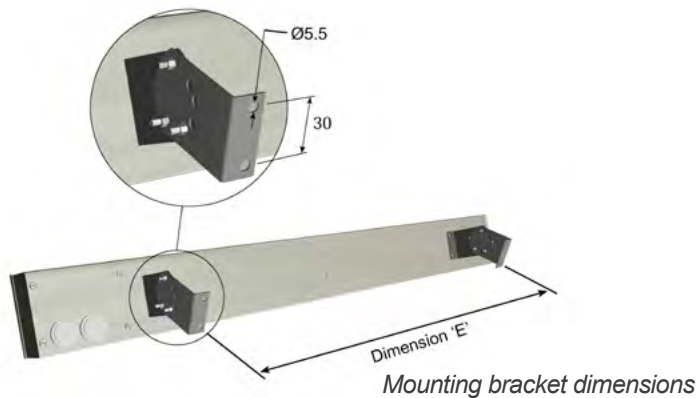

Minimum Mounting Distances

	Description	Minimum Distance
A	Heater to adjacent wall	300mm
B	Heater to flammable material	800mm
C	Heater to floor	2300mm
D	Heater to ceiling	150mm





Frenger IRI



Frenger IRI Radiant Heater

Introduction

The IRI Industrial range provides energy efficient heating for most applications and working environments with high ceiling heights (approx. 3 - 40m or 3.5m in zone heating applications). Heat accumulation in floors, walls and other surfaces means that the air temperature can be lowered giving 25 - 50% energy savings and yet achieving the same ambient temperature. The Frenger IRI Industry is also often used to provide spot heating to loading bays, manufacturing facilities and various agricultural buildings.

The heaters are approved to IP44 and can as such be used in wet and dry areas alike.

Benefits of Radiant Heating

- Possible to maintain 3 - 6°C lower air temperature than with conventional heating.
- Concentrates heat to the occupied zone.
- Minimising warm - up times.

Benefits of Frenger IRI

- No moving parts equates to reduced maintenance costs.
- Ceiling mounted unit frees up wall and floor space.
- Suitable for mounting between 5 - 40m from floor level.
- Robust design.
- Splash proof IP44.

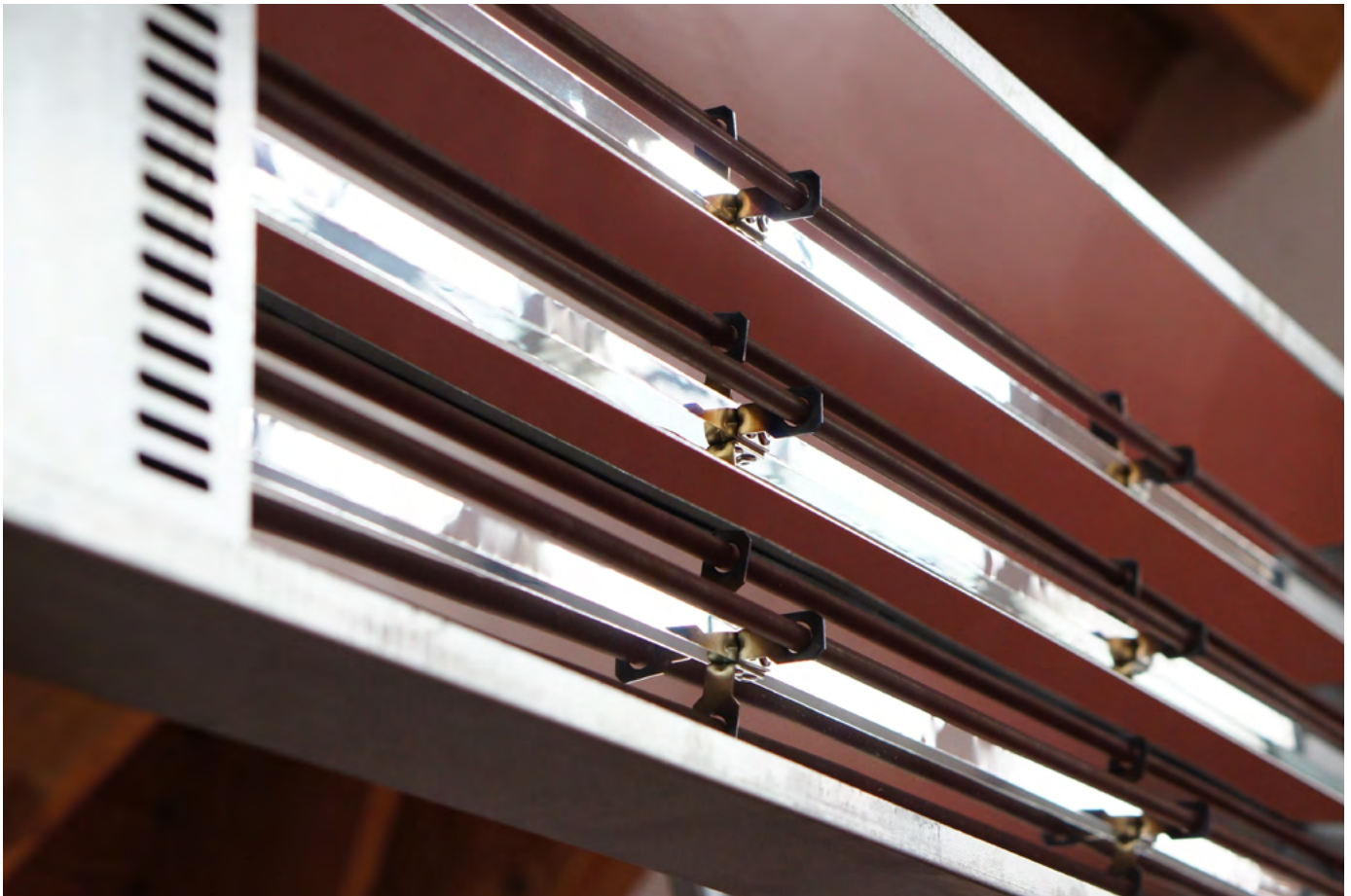

Technical Data

Part No.	Heating Capacity (W)	Voltage (V)	Size (LxWxD) mm	Weight (Kg)
IRI3000	3000	400	1030 x 300 x 80	5.5
IRI4500	4500	400	1360 x 300 x 80	7.0
IRI6000	6000	400	1680 x 300 x 80	8.5

Control

Frenger can supply a range of suitable thermostats to be used with the Frenger IRI at an additional cost. Should you require any assistance in selection please contact our technical sales department.

Design

Frenger IRI units consists of 3 heating element and shiny anodised aluminium reflectors, all of which held in a robust outer casing constructed from galvanised sheet steel (for corrosion protection) unit left self finished for an industrial appearance (dull grey, no paint finish).

Frenger IRI heaters have a solid stainless steel round bar as the heat emitter element, not glass tubes that emit unwanted light, as associated with competitors Quartz and Halogen tube emitters.



Mounting & Installation

Bracket Distances

Frenger IRI offers easy installation using the included adjustable mounting brackets. The brackets can be adjusted to angle the heater in different positions enabling direction of the heat to the desired areas.

The heaters can also be suspended from chains, wires etc.. (suspension equipment by others).

Part No.	IRI3000	IRI4500	IRI6000
Dimensions 'E' (mm)	650	820	1030

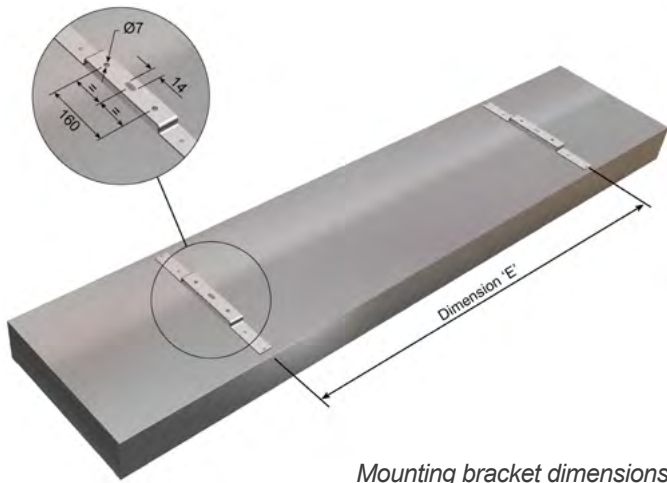

Mounting bracket dimensions

Supplied bracket maintains the minimum mounting distance for the selected product (distance D, below)

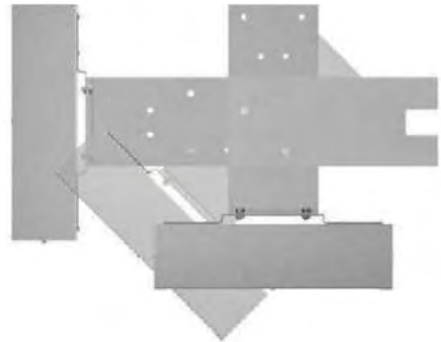

Adjustable mounting bracket

Minimum Mounting Distances

	Description	Minimum Distance
A	Heater to wall	500mm
B	Heater to floor (spot heating)	2500mm *
B	Heater to floor (total heating)	4500mm *
C	Heater to flammable material	1500mm
D	Heater to ceiling	200mm - if wall mounted, 300mm - if ceiling mounted

* Dependant on model. Contact Frenger's technical department for further information.



Minimum mounting distances

LEITCH & GH

LEITCH & GH



Accessories

T60-EH Controller

Frenger's T60-EH controller allows for the control of the Electric Radiant Heaters (not applicable for Frenger's Air Curtain range) to create a balanced and ideal indoor climate to suit your needs.

Frenger's T60-EH controller is a 5-day plus weekends electronic programmable **colour touch screen controller with an in-built Thermostat and Humidity Sensor**. The controller has three programming modes to help improve efficiency of the system:

- Weekday/Weekend
- Seven Day
- 24-hour mode

The controller is suitable for flush mounting and requires a minimum 35mm deep junction box which is recessed into the wall.

The 'Away Mode' is a shortcut button to easily change to a preset temperature when leaving the premises. The range is 7-35°C, default setting is 7°C. In 'Away Mode', the T60 controller will only turn the heating ON if/when the room temperature drops below a set 'Away Temperature'.

This set temperature can be changed in the settings to suit your needs.

Integrated within the controller is a Humidity Sensor, which when selected on the controller shows the air humidity in the indoor environment as well as temperature.

The T60 controller features a Hold mode which allows the user to manually override the current operating program and set a different temperature for a desired period. The temperature range for this function is 5°C to 45°C.

Holiday mode is another key feature of the T60 controller. When activated the unit will maintain the temperature for the duration of the holiday time entered and will then automatically return to the program mode on the users return.

Finally, the Schedule setting on the T60 controller allows the user to set certain temperatures at four pre-determined time sections: Morning, Day, Evening, and Night. This feature helps the user to create a comfortable and ideal indoor climate environment for the benefit of building occupants.

Max output: 230V~16A

For further information please contact Frenger's technical department on technical@frenger.co.uk.



Bespoke Manufacturing

Frenger has the manufacturing capability required to deliver the most complex of bespoke solutions. Facilities include the latest full CNC machine centers, together with a dedicated powder-coat paint plant to paint all of the components of the products and project specific in-house testing laboratories.



Project Specific Testing Facility

The 3 number state-of-the-art Climatic Testing Laboratories at Frenger's technical facility in Derby (UK) have internal dimensions of 6.3m (L) x 5.7m (W) x 3.3m (H) high and includes a thermal wall so that both internal and perimeter zones can be simulated. Project specific testing validates product / solution performance (outputs) and resultant Room Comfort Conditions for compliance category grading in accordance with BS EN ISO 7730. All of Frenger's chilled beams have also been independently tested and certified by Eurovent in terms of product performance (output), as Eurovent can not test for thermal comfort; hence the need for Frenger's own laboratories.

Project Specific Testing

Project specific mock-up testing is a valuable tool which allows the Client to fully assess the proposed system and determine the resulting room occupancy Thermal Comfort conditions. The physical modelling is achieved by installing a full scale representation of a building zone complete with internal & external heat gains (Lighting, Small Power, Occupancy & Solar Gains).

The installed mock-up enables the client to verify the following:

- Product performance under project specific conditions.
- Spatial air temperature distribution.
- Spatial air velocities.
- Experience thermal comfort.
- Project specific aesthetics.
- Experience lighting levels (where relevant).
- Investigate the specific design and allow the system to be optimised.



The project-specific installation and test is normally conducted to verify:

- Product capacity under design conditions.
- Comfort levels - air temperature distribution.
 - thermal stratification.
 - draft risk.
 - radiant temperature analysis.
- Smoke test video illustrating air movement.
- Live Thermal Imaging

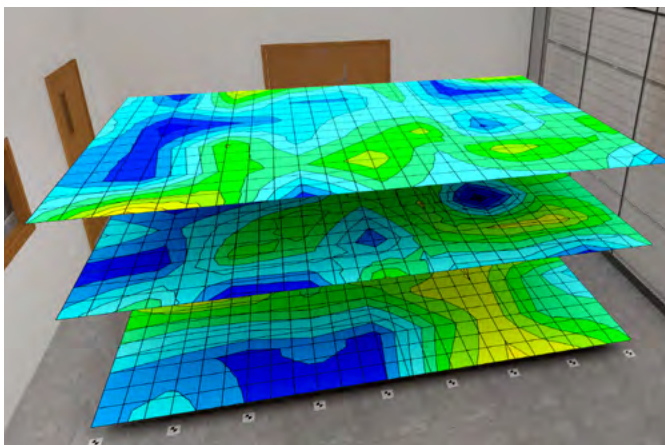

Photometric Testing Facility

The in-house Photometric test laboratories at Frenger are used to evaluate the performance of luminaires. To measure the performance, it is necessary to obtain values of light intensity distribution from the luminaire. These light intensity distributions are used to mathematically model the lighting distribution envelope of a particular luminaire. This distribution along with the luminaires efficacy allows for the generation of a digital distribution that is the basis of the usual industry standard electronic file format. In order to assess the efficacy of the luminaire it is a requirement to compare the performance of the luminaire against either a calibrated light source for absolute output or against the “bare” light source for a relative performance ratio.

The industry uses both methods. Generally absolute lumen outputs are used for solid state lighting sources and relative lighting output ratios (LOR) are used for the more traditional sources. Where the LOR method is chosen then published Lamp manufacturer’s data is used to calculate actual lighting levels in a scheme and for LED light source the integration chamber is used to measure LED luminance efficacy.

The intensity distribution is obtained by the use of a Goniophotometer to measure the intensity of light emitted from the surface of the fitting at pre-determined angles. The light intensity is measured using either a photometer with a corrective spectral response filter to match the CIE standard observer curves or our spectrometer for LED sources.

Luminaire outputs are measured using our integrating sphere for smaller luminaires or our large integrator room for large fittings and Multi Service Chilled Beams. For both methods we can use traceable calibrated radiant flux standards for absolute comparisons.

All tests use appropriate equipment to measure and control the characteristics of the luminaire and include air temperature measurements, luminaire supply voltage, luminaire current and power. Thermal characteristics of luminaire components can be recorded during the testing process as required.

A full test report is compiled and supplied in “locked” PDF format. Data is collected and correlated using applicable software and is presented electronically to suit, usually in Eulumdat, CIBSE TM14 or IESN standard file format.

Frenger conduct photometric tests in accordance with CIE 127:2007 and BS EN 13032-1 and sound engineering practice as applicable. During the course of these tests suitable temperature measurements of parts of LED’s can be recorded. These recorded and plotted temperature distributions can be used to provide feedback and help optimise the light output of solid state light source based luminaires which are often found to be sensitive to junction temperatures.

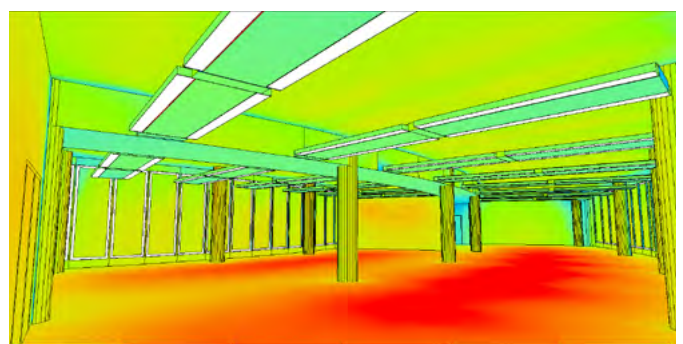
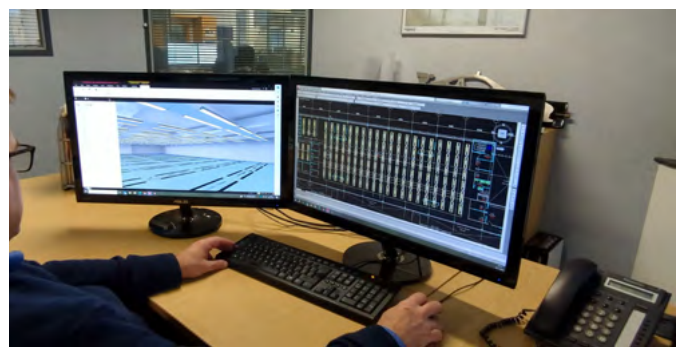
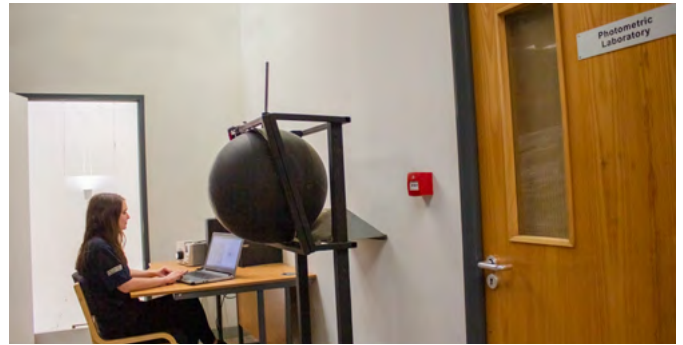

Acoustic Testing Facility

The Acoustic Test Room at Frenger is a hemi-anechoic chamber which utilises sound absorbing acoustic foam material in the shape of wedges to provide an echo free zone for acoustic measurements; the height of the acoustic foam wedge has a direct relationship with the maximum absorption frequency, hence Frenger had the acoustic wedges specifically designed to optimise the sound absorption at the peak frequency normally found with our active chilled beam products.

The use of acoustic absorbing material within the test room provides the simulation of a quiet open space without “reflections” which helps to ensure sound measurements from the sound source are accurate, in addition the acoustic material also helps reduce external noise entering the test room meaning that relatively low levels of sound can be accurately measured.

The acoustic facilities allow Frenger to provide express in-house sound evaluation so that all products, even project specific designs can be quickly and easily assessed and optimised.

To ensure accuracy, Frenger only use Class 1 measurement equipment which allows sound level measurements to be taken at 11 different $\frac{1}{3}$ octave bands between 16 Hz to 16 kHz, with A, C and Z (un-weighted) simultaneous weightings.

In addition to the above, Frenger also send their new products to specialist third party Acoustic Testing. The results of which are very close and within measurement tolerances to that of Frenger’s in-house measurement of sound.

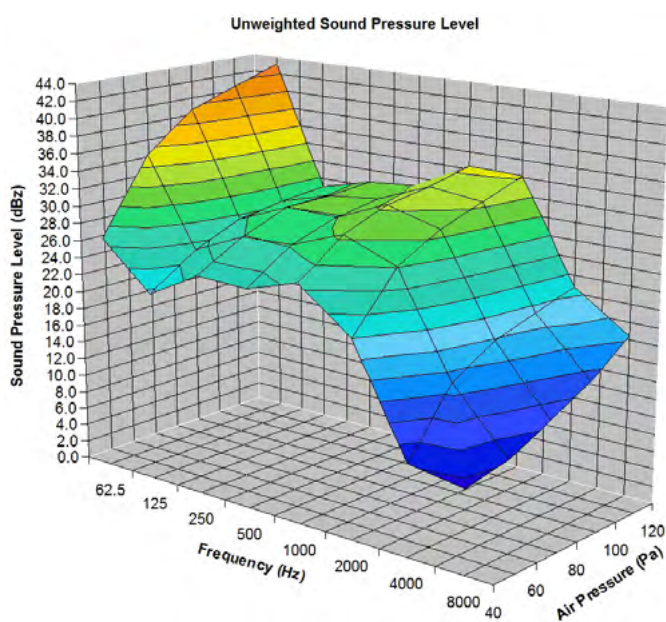
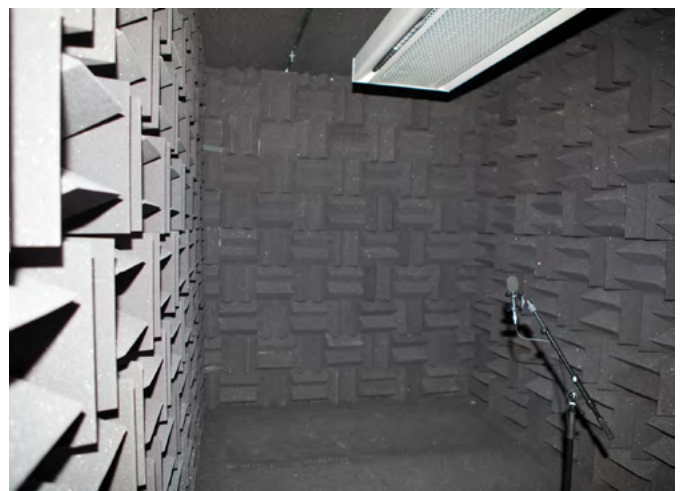

Industry Associations

Always mindful of its place within the HEVAC industry, Frenger Systems pride themselves on broad range of trade associations and accreditations. With a clear service, product and environmental ethos across everything they do, Frenger is focused on meeting and consistently surpassing the expectations of its customers. Frenger invest heavily in achieving industry recognised accreditations and as part of ongoing commitment to their customers and continually assess the level of services they provide. Opening up their company to these independent organisations allows Frenger to continually improve their customer service and satisfaction.

As an engaged member of the HEVAC industry, Frenger are actively asked to participate in industry specific discussions and studies. With this in mind Frenger are proud to have achieved and be linked with the following associations:



BSI EN ISO 9001:2015

Frenger Systems are registered by BSI for operating a Quality Management System which complies with the requirements of BS EN 9001:2015.



Eurovent

Frenger Systems participate in the EC programme for Chilled Beams. Check ongoing validity of certificate: www.eurovent-certification.com or www.certiflash.com . The heat exchanger for the Recepto HRU is a Klingenburg Eurovent Certified aluminium static heat exchanger.



Chilled Beam and Ceiling Association

The Chilled Beam and Ceiling Association has been formed by leading companies within the construction industry. The objective of the Association is to promote the use of Chilled Beams and Chilled Ceilings, and encourage best practice in their development and application.



HEVAC Member

HEVAC is the heating and ventilating contractors association. As a HEVAC member Frenger Systems are subject to regular, third party inspection and assessment to ensure their technical and commercial competence.



Federation of Environment Trade Association

The Federation of Environment Trade Association (FETA), of which Frenger Systems is a member of, is the recognised UK body which represents the interests of manufacturers, suppliers, installers and contractors within the heat pump, controls, ventilating, refrigeration & air conditioning industry.



UK Trade & Investment

Frenger Systems are members of both the UK TI (the former Department of Trade and Industry) as well as the Chamber of Commerce for Export Documentation.



Certified CIBSE CPD

Frenger Systems is a CIBSE approved "Continued Professional Development" (CPD) provider. Frenger offers 1 hour lunch time CPD presentations regarding "Chilled Beam Technology", CPD presentations are usually held at Consulting Engineers local practices with lunch provided courtesy of Frenger. Alternatively half or full day Chilled Beam Technology training is available at Frenger's UK Technical Academy in a dedicated training theatre with fully operational BMS system with various different Chilled Beam and Ceiling solutions integrated.

Booking of a CPD Presentation can be requested on Frenger's home page, under the drop down menu headed "Company", then "CPD Booking". Alternatively email sales@frenger.co.uk.



UK Head Office

Frenger System Ltd
Riverside Road
Pride Park
Derby
DE24 8HY

tel: +44 0 1332 295 678
sales@frenger.co.uk
www.frenger.co.uk

Australian Office

Frenger
Level 20
Tower 2
201 Sussex Street
Sydney
NSW 2000
Australia

tel: +61 2 9006 1147
sales@frenger.com.au
www.frenger.com.au

American Office

FTF Group Climate
Bryant Park
104 W40th Street
Suite 400 & 500
New York
NY 10018
United States of America

tel: +00 1 (646) 571-2151
sales@ftfgroup.us
www.ftfgroup.us



Frenger is an **FTF Group** Company
Registered No. 646 6229 20

www.frenger.co.uk